

Aluminum and cast iron helical bevel gearboxes

A modular and compact product
Very energy efficient drive

Removable inspection cover

Allows periodic inspection of gearing during routine maintenance

Gears

Hardened and ground gears

Alloy housing

Is vacuum impregnated (MIL-STD 276) for protection and sealing. No secondary finish required but readily accepts paint.

Oil seals

Two oil seals on request

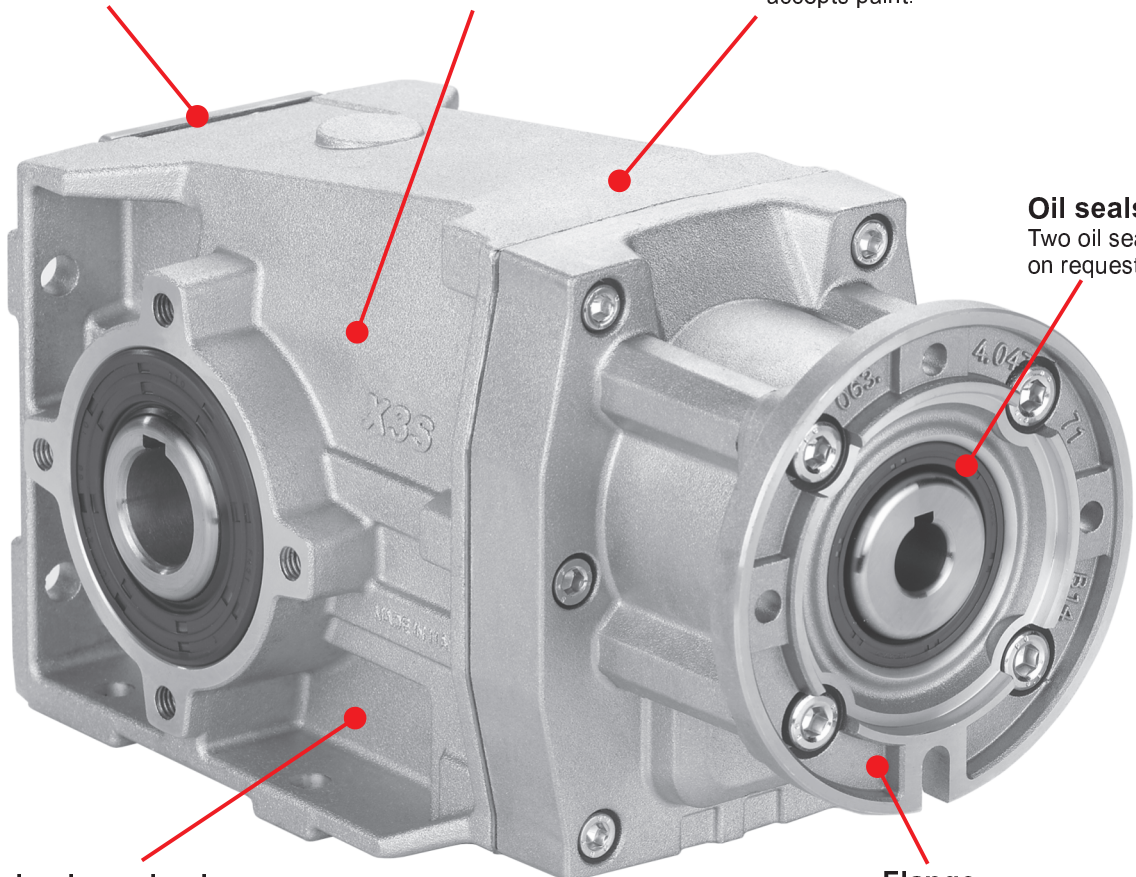

Single-piece aluminum

Combines light weight with high tensile strength. Precision machined for alignment of bearings and gearing

Flange

Fully modular to IEC and Compact integrated motor. NEMA C flange

Cast Iron housing

With high tensile strength. Precision machined for alignment of bearings and gearing

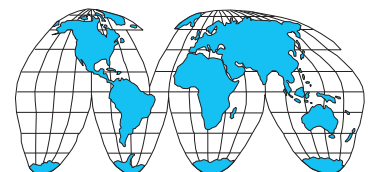
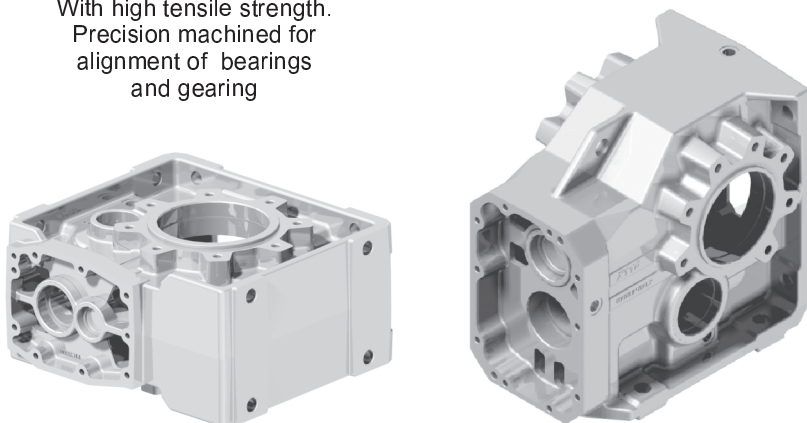

World wide sales network.

Specific type datasheet on page...

On page / A pagina / Auf Seite / À la page / En la página

8-5	8-7	8-9	8-11	8-13	8-15	8-17	8-19	8-21
X22S 50Nm	X32S 90Nm	X33S 100Nm	X42A 150Nm	X43A 160Nm	X52A 250Nm	X53A 250Nm	X62A 410Nm	X63A 410Nm

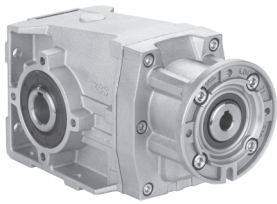

Types / Tipi
Typen / Types
Tipos

On page / A pagina / Auf Seite / À la page / En la página

8-23	8-25	8-27	8-29	8-31	8-33	8-35	8-37	8-39	8-41
X73C 675Nm	X74C 675Nm	X83C 1000Nm	X84C 1000Nm	X93C 1600Nm	X94C 1650Nm	X103 3000Nm	X104 3000Nm	X113 4500Nm	X114 4600Nm

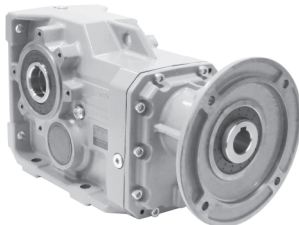

Types / Tipi
Typen / Types
Tipos

On page / A pagina / Auf Seite / À la page / En la página

8-43	8-45	8-47	8-49
113C 675Nm	114C 675Nm	133C 1000Nm	134C 1000Nm

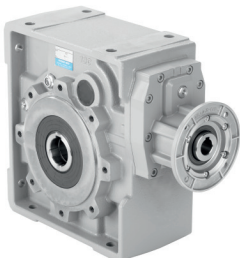

Types / Tipi
Typen / Types
Tipos

On page / A pagina / Auf Seite / À la page / En la página

M-1									
56A 56B	63A 63B	71A 71B	80A 80B	90S 90L	100LA 100LB	112M	132S 132M	160M 160L	180M 180L

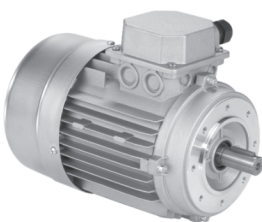



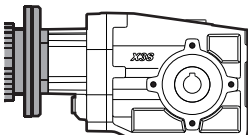
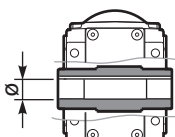
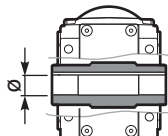
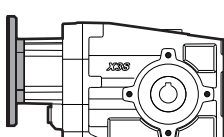
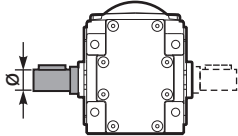
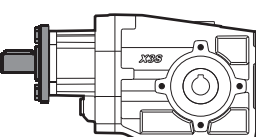
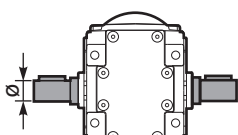
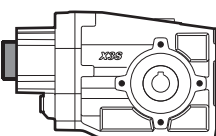
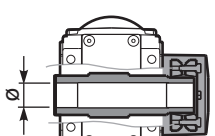
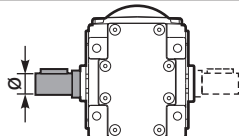
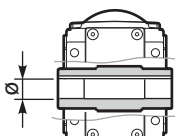
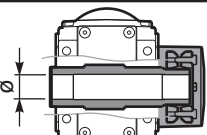

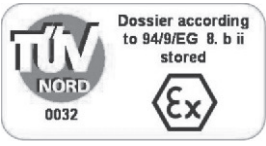



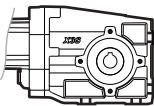
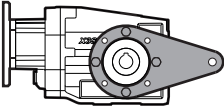
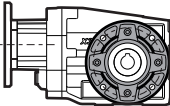
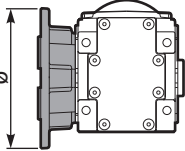

Types / Tipi
Typen / Types
Tipos

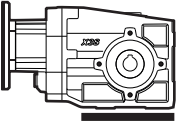
Type - Tipo - Typ Type - Tipo	Size - Grandezza - Größe Taille - Tomaño	Mounting - Montaggio Montage - Fixation Tipo de montaje	Rapporto - Ratio Untersetzung Reduction Relacion	Output shaft - Albero uscita Ausgangsflansch Arbre de sortie Brida en solida																																		
M	X22S	C	4.83	-A																																		
<p>Helical-bevel gear Riduttori ortogonali</p>  <p>With IEC motor M</p>	<p>2 Stages Riduzioni Stufen Trains Etapas</p> <p>3 Stages Riduzioni Stufen Trains Etapas</p> <p>Aluminum Alluminio Aluminium Aluminio</p>	 <p>Hollow output shaft C</p>	<p>See technical data table</p> <p>Vedi tabella dati tecnici.</p> <p>Technisches Datenblatt beachten</p> <p>Voir Tableau données techniques</p> <p>Ver tabla datos técnicos</p>	 <p>→ STANDARD</p> <p>Hollow output shaft</p> <table border="1"> <tr> <td>X22S</td> <td>X73/4C X83/4C</td> </tr> <tr> <td>-A → $\varnothing 18$</td> <td>-F → $\varnothing 40$</td> </tr> <tr> <td>-B → $\varnothing 20$</td> <td>-H → $\varnothing 45$</td> </tr> <tr> <td></td> <td>113C 114C</td> </tr> <tr> <td>X32S X33S</td> <td>-F → $\varnothing 40$</td> </tr> <tr> <td>-B → $\varnothing 20$</td> <td>-G → $\varnothing 42$</td> </tr> <tr> <td>-C → $\varnothing 25$</td> <td>133C 134C</td> </tr> <tr> <td>X42A X43A</td> <td>-F → $\varnothing 40$</td> </tr> <tr> <td>-C → $\varnothing 25$</td> <td>-H → $\varnothing 45$</td> </tr> <tr> <td>-D → $\varnothing 30$</td> <td>X93C X94C</td> </tr> <tr> <td>X52A X53A</td> <td>-H → $\varnothing 45$</td> </tr> <tr> <td>-D → $\varnothing 30$</td> <td>-J → $\varnothing 50$</td> </tr> <tr> <td>-E → $\varnothing 35$</td> <td>X103 X104</td> </tr> <tr> <td>X62A X63A</td> <td>-K → $\varnothing 60$</td> </tr> <tr> <td>-E → $\varnothing 35$</td> <td>X113 X114</td> </tr> <tr> <td>-F → $\varnothing 40$</td> <td>-T → $\varnothing 70$</td> </tr> </table>	X22S	X73/4C X83/4C	-A → $\varnothing 18$	-F → $\varnothing 40$	-B → $\varnothing 20$	-H → $\varnothing 45$		113C 114C	X32S X33S	-F → $\varnothing 40$	-B → $\varnothing 20$	-G → $\varnothing 42$	-C → $\varnothing 25$	133C 134C	X42A X43A	-F → $\varnothing 40$	-C → $\varnothing 25$	-H → $\varnothing 45$	-D → $\varnothing 30$	X93C X94C	X52A X53A	-H → $\varnothing 45$	-D → $\varnothing 30$	-J → $\varnothing 50$	-E → $\varnothing 35$	X103 X104	X62A X63A	-K → $\varnothing 60$	-E → $\varnothing 35$	X113 X114	-F → $\varnothing 40$	-T → $\varnothing 70$		
X22S	X73/4C X83/4C																																					
-A → $\varnothing 18$	-F → $\varnothing 40$																																					
-B → $\varnothing 20$	-H → $\varnothing 45$																																					
	113C 114C																																					
X32S X33S	-F → $\varnothing 40$																																					
-B → $\varnothing 20$	-G → $\varnothing 42$																																					
-C → $\varnothing 25$	133C 134C																																					
X42A X43A	-F → $\varnothing 40$																																					
-C → $\varnothing 25$	-H → $\varnothing 45$																																					
-D → $\varnothing 30$	X93C X94C																																					
X52A X53A	-H → $\varnothing 45$																																					
-D → $\varnothing 30$	-J → $\varnothing 50$																																					
-E → $\varnothing 35$	X103 X104																																					
X62A X63A	-K → $\varnothing 60$																																					
-E → $\varnothing 35$	X113 X114																																					
-F → $\varnothing 40$	-T → $\varnothing 70$																																					
 <p>With motor flange P</p>	<p>X22S X32S X42A X52A X62A</p>	 <p>Single output shaft A</p>																																				
 <p>With male input shaft R</p>	<p>X33S X43A X53A X63A</p>	 <p>Double output shaft only for 113/4C, 133/4C, X73/4C, X83/4C, X93/4C, X103/4 and X113/4 B</p>																																				
 <p>Modular base B</p> <p>Not available for: X93C, X103, X104, X113, X114.</p>	<p>3 Stages Riduzioni Stufen Trains Etapas</p> <p>4 Stages Riduzioni Stufen Trains Etapas</p> <p>Cast Iron Ghisa Grauguss Fonte Fundicion</p> <table border="1"> <tr> <td>113C</td> <td>114C</td> </tr> <tr> <td>133C</td> <td>134C</td> </tr> <tr> <td>X73C</td> <td>X74C</td> </tr> <tr> <td>X83C</td> <td>X84C</td> </tr> <tr> <td>X93C</td> <td>X94C</td> </tr> <tr> <td>X103</td> <td>X104</td> </tr> <tr> <td>X113</td> <td>X114</td> </tr> </table>	113C	114C	133C	134C	X73C	X74C	X83C	X84C	X93C	X94C	X103	X104	X113	X114	 <p>Shrink Disk (only on the DX side) D</p> <p>Only on request for Q.ty A richiesta per quantità</p>		 <p>Single and double output shaft</p> <table border="1"> <tr> <td>-I</td> <td>X22S X32/3S → $\varnothing 20$</td> </tr> <tr> <td>-L</td> <td>X32/3S X42/3A → $\varnothing 25$</td> </tr> <tr> <td>-M</td> <td>X52/3A → $\varnothing 30$</td> </tr> <tr> <td>-N</td> <td>X52/3A X62/3A X73/4A* → $\varnothing 35$</td> </tr> <tr> <td>-V</td> <td>X83/4A 113/4C → $\varnothing 40^*$</td> </tr> <tr> <td>-O</td> <td>113/4C → $\varnothing 42^*$</td> </tr> <tr> <td>-P</td> <td>133/4C → $\varnothing 45^*$</td> </tr> <tr> <td>-1</td> <td>X93/4C → $\varnothing 50^*$</td> </tr> <tr> <td>-3</td> <td>X103/4 → $\varnothing 60^*$</td> </tr> <tr> <td>-5</td> <td>X113/4 → $\varnothing 70^*$</td> </tr> </table> <p>* Also available double output shaft</p>	-I	X22S X32/3S → $\varnothing 20$	-L	X32/3S X42/3A → $\varnothing 25$	-M	X52/3A → $\varnothing 30$	-N	X52/3A X62/3A X73/4A* → $\varnothing 35$	-V	X83/4A 113/4C → $\varnothing 40^*$	-O	113/4C → $\varnothing 42^*$	-P	133/4C → $\varnothing 45^*$	-1	X93/4C → $\varnothing 50^*$	-3	X103/4 → $\varnothing 60^*$	-5	X113/4 → $\varnothing 70^*$
113C	114C																																					
133C	134C																																					
X73C	X74C																																					
X83C	X84C																																					
X93C	X94C																																					
X103	X104																																					
X113	X114																																					
-I	X22S X32/3S → $\varnothing 20$																																					
-L	X32/3S X42/3A → $\varnothing 25$																																					
-M	X52/3A → $\varnothing 30$																																					
-N	X52/3A X62/3A X73/4A* → $\varnothing 35$																																					
-V	X83/4A 113/4C → $\varnothing 40^*$																																					
-O	113/4C → $\varnothing 42^*$																																					
-P	133/4C → $\varnothing 45^*$																																					
-1	X93/4C → $\varnothing 50^*$																																					
-3	X103/4 → $\varnothing 60^*$																																					
-5	X113/4 → $\varnothing 70^*$																																					
		 <p>Stainless steel hub I</p> <p>Stainless steel hub Mozzo in acciaio Inox Edelstahlhohlwelle Moyeu en acier Inox Nucleo corona de acero Inox</p> <p>Only on request for Q.ty A richiesta per quantità</p>		 <p>Shrink Disk</p> <table border="1"> <tr> <td>-U</td> <td>X22S X32/3S → $\varnothing 20$</td> </tr> <tr> <td>-Q</td> <td>X42/3A → $\varnothing 30$</td> </tr> <tr> <td>-R</td> <td>X52/3A → $\varnothing 35$</td> </tr> <tr> <td>-S</td> <td>X62/3A X73/4A X83/4A 113/4C → $\varnothing 40$</td> </tr> <tr> <td>-6</td> <td>133/4C → $\varnothing 45$</td> </tr> <tr> <td>-7</td> <td>X93/4C → $\varnothing 50$</td> </tr> <tr> <td>-8</td> <td>X103/4 → $\varnothing 65$</td> </tr> <tr> <td>-9</td> <td>X113/4 → $\varnothing 75$</td> </tr> </table>	-U	X22S X32/3S → $\varnothing 20$	-Q	X42/3A → $\varnothing 30$	-R	X52/3A → $\varnothing 35$	-S	X62/3A X73/4A X83/4A 113/4C → $\varnothing 40$	-6	133/4C → $\varnothing 45$	-7	X93/4C → $\varnothing 50$	-8	X103/4 → $\varnothing 65$	-9	X113/4 → $\varnothing 75$																		
-U	X22S X32/3S → $\varnothing 20$																																					
-Q	X42/3A → $\varnothing 30$																																					
-R	X52/3A → $\varnothing 35$																																					
-S	X62/3A X73/4A X83/4A 113/4C → $\varnothing 40$																																					
-6	133/4C → $\varnothing 45$																																					
-7	X93/4C → $\varnothing 50$																																					
-8	X103/4 → $\varnothing 65$																																					
-9	X113/4 → $\varnothing 75$																																					

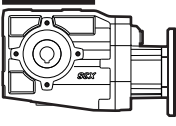
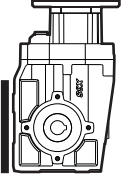
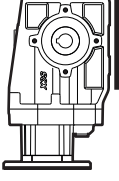
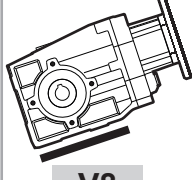
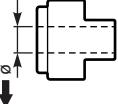
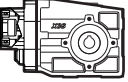

On request we can deliver our products according to the ATEX
 A richiesta possiamo fornire i nostri prodotti secondo le normative ATEX
 Auf Anfrage können wir unsere Produkte den Richtlinien ATEX entsprechend liefern
 Sur demande nos produits peuvent se conformer à la réglementation ATEX
 A pedido, se pueden enviar nuestros productos de acuerdo con las normas ATEX.

Type - Tipo - Typ Type - Tipo	Output flange Flangia di uscita Ausgangs Flansch Bride de sortie Brida en salida	Motor size - Grandezza motore Motor Größe Grandeur moteur - Tamaño motor	Mounting position Posizione montaggio Einbaulage Position de montage Position de montage	Input bore Foro entrata Eingangshohlwelle Trou d'entree Eje hueco de entrada	Terminal box position Posizione morsettieria Klemmkastenlage Position boîte à bornes Posición caja de bornes	
BR	N	-O	B3	-		
 <p>FB Forma base Universal</p>  <p>BR Braccio d reazione Reaction arm</p>  <p>-F Flangia uscita output flange</p>	 <p>N Senza flangia Without flange X22S</p> <p>0 ⇒ Ø110 1 ⇒ Ø120</p> <p>X32S X33S</p> <p>1 ⇒ Ø120 2 ⇒ Ø160</p> <p>X42-3A X52-3A X62-3A</p> <p>2 ⇒ Ø160 3 ⇒ Ø200 4 ⇒ Ø250</p> <p>X73C X74C X83C X84C</p> <p>4 ⇒ Ø250</p> <p>113C 114C X93C X94C</p> <p>C ⇒ Ø280 L ⇒ Ø280</p> <p>133C 134C</p> <p>C ⇒ Ø320</p> <p>X103 X104</p> <p>6 ⇒ Ø350</p> <p>X113 X114</p> <p>7 ⇒ Ø450</p>	 <p>Flange Flangia</p> <p>B5</p> <p>-A=56 (Ø120) -B=63 (Ø140) -C=71 (Ø160) -D=80 (Ø200) -E=90 (Ø200) -F=100+112 (Ø250) -G=132 (Ø300) -H=160 (Ø350) -I=180 (Ø350) -L=200 (Ø400) CA=225 (Ø450)</p> <p>B14</p> <p>-O=56 (Ø80) -P=63 (Ø90) -Q=71 (Ø105) -R=80 (Ø120) -T=90 (Ø140) -U=100+112 (Ø160) -V=132 (Ø200)</p>  <p>Type R Tipo R</p> <p>X22S X33S X43A</p> <p>-1 ⇒ Ø14</p> <p>X32S X42A X53A X63A X74C X84C 114C 134C</p> <p>-2 ⇒ Ø19</p> <p>X52A X62A 113C 133C X73C X83C X94C</p> <p>-3 ⇒ Ø24</p> <p>X93C X104 X114</p> <p>-4 ⇒ Ø28</p> <p>X103 X113</p> <p>-6 ⇒ Ø42</p>	 <p>Without flange Senza flangia</p> <p>-M ⇒ With coupling X22S X33S X43A</p> <p>-Z ⇒ Ø9 (56B5) -0 ⇒ Ø11 (63B5) -1 ⇒ Ø14 (71B5)</p> <p>X32S X42A X53A X63A X74C X84C 114C 134C</p> <p>-1 ⇒ Ø14 (71B5) -2 ⇒ Ø19 (80B5) -3 ⇒ Ø24 (90B5)</p> <p>X52A X62A 113C 133C X73C X83C X94C</p> <p>-2 ⇒ Ø19 (80B5) -3 ⇒ Ø24 (90B5) -4 ⇒ Ø28 (100B5)</p>	 <p>B3 STANDARD</p>  <p>B6</p>  <p>B7</p>  <p>B8</p>  <p>V5</p>  <p>V6</p>  <p>V8</p>	<p>-</p> <p>Nothing indication: standard bore</p> <p>Nessuna indicazione: foro standard</p> <p>COUPLING</p>  <p>A = 9mm B = 11mm C = 14mm D = 19mm E = 24mm F = 28mm</p> <p>0</p> <p>Ready for input coupling Predisposto per giunto</p> 	<p>With Type M specify terminal box position Con tipo M specificare posizione morsettieria</p>  <p>A</p>  <p>B STANDARD</p>  <p>C</p>  <p>D</p>

POTENZA RICHIESTA / REQUIRED POWER / ERFORDERLICHE LEISTUNG / PUISSANCE NECESSAIRE / POTENCIA NECESARIA

Lifting / sollevamento / hubantriebe / levage / elevación

$$P [KW] = \frac{M [Kg] \cdot g [9.81] \cdot v [m / s]}{1000}$$

Rotation / rotazione / drehung / rotation / rotacion

$$P [KW] = \frac{M [Nm] \cdot n [rpm]}{9550}$$

Linear movement / traslazione / linearbewegung / translation / translacion

$$P [KW] = \frac{F [N] \cdot v [m / s]}{1000}$$

TORQUE / COPPIA / DREHMOMENT / COUPLE / PAR

$$M [Nm] = \frac{9550 \cdot P[KW]}{n [rpm]}$$

$$M [lb in] = \frac{63030 \cdot P[HP]}{n [rpm]}$$

RADIAL LOADS / CARICHI RADIALI / RADIALE - UND AXIALLASTEN / CHARGES RADIALES / CARGA RADIAL Y AXIAL

- Radial load generated by external transmissions keyed onto input and/or output shafts.
- Forza radiale generata da organi di trasmissione calettati sugli alberi di ingresso e/o uscita.
- Belastungen der Antriebs- bzw. Abtriebswellen durch von aussen eingebrachte Radiallasten.
- Charge radiale générée par la transmissions calés sur les entrées et / ou des arbres de sortie
- Cargas radiales, generada por transmisiones externas, aplicadas sobre los ejes de entrada y/o salida

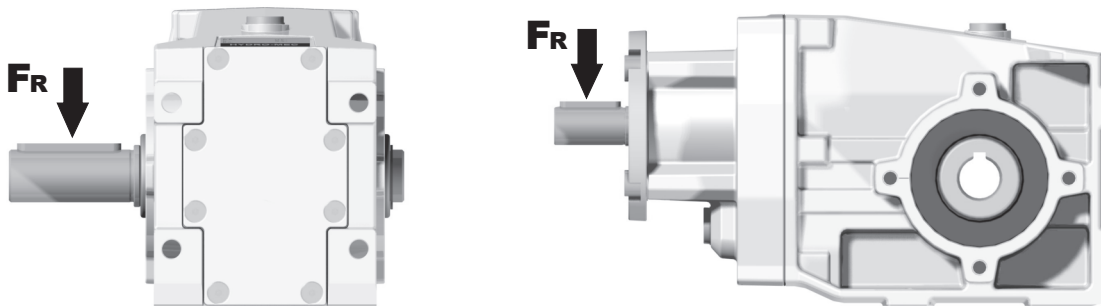

$$F_R [N] = \frac{M [Nm] \cdot 2000}{d [mm]} \cdot f_k$$

$$F_R [N] = \frac{M [lb in] \cdot 8.9}{d [in]} \cdot f_k$$

M	Momento torcente / Output torque / Abtriebsdrehmoment / Couple / Par torsion
d	Diametro primitivo / Diam. of driving element / Durchmesser der Abtriebseinheit / Diamètre primitif / Diámetro primitivo
f_k	Coefficiente di trasformazione / Factor / Faktor / Coefficient de transmission / Coeficiente de transmisión 1.15 Ingranaggi / Gearwheels / Zahnrad / Engrenage / Engranaje 1.25 Catena / Chain sprockets / Antriebskette / Chaîne / Cadena 1.75 Cinghia Trapezoidale / Narrow v-belt pulley / Keilriemen / Courroie trap. / Correa trapezoidal 2.50 Cinghia piatta / Flat-belt pulley / Flachzahnriem. / Courroie crantée / Correa plana

- If your application requires higher radial loads, contact our technical office. Higher load may be possible.
- Nel caso la vostra applicazione richieda carichi radiali superiori consultare il nostro ufficio tecnico, valori maggiori possono essere accettati.
- Wenn Ihre Anwendung höhere Radialbelastungen erfordert, so wenden Sie sich bitte an unser technischen Büro.
- Si votre application demande des charges radiales supérieures, s'adresser à notre bureau technique.
- En el caso en que una aplicación exija una carga radial superior a la especificada en el catálogo, consultar a nuestra oficinas técnica.

How to select a gearbox / Come selezionare un riduttore / Wie wählt man ein Getriebe
Comment sélectionner un réducteur / Cómo seleccionar un reductor

B Output speed
Velocità in uscita
Abtriebsdrehzahl
Vitesse de sortie
Velocidad de salida

Nominal power
Potenza nominale
Max. mögliche Leistung
Poissance nominale
Potencia nominal

Gear size
Grandezza riduttore
Getriebegröße
Taille réducteur
Tamaño reductor

Motor power
Potenza motore
Motorleistung
Puissance moteur
Potencia motor

A Nominal torque
Momento torcente nominale
Nenn Drehmoment
Couple nominal
Par de torsión nominal

Flange code
Codice flangia
Flanschtype
Code bride
Código bridas

Input speed
Velocità in entrata
Eintriebsdrehzahl
Vitesse en entrée
Velocidad de entrada

X22S Angletech Gear **50Nm** Rating - Aluminum
HELICAL-BEVEL GEARBOXES

QUICK SELECTION / Selezione veloce The dynamic efficiency is 0.96 for all ratios input speed (n₁) = 1400 min⁻¹

Output Speed n ₂ [min ⁻¹]	Ratio i	Motor power P _{1M} [kW]	Output torque M _{2M} [Nm]	Service factor f.s.	Nominal power P _{1R} [kW]	Nominal torque M _{2R} [Nm]	Available B5 motor flanges		Available B14 motor flanges			Output Shaft	Ratios code
							-B	-C	-O	-P	-Q		
289.7	4.83	0.37	11.7	2.6	0.95	30	63	71	C	C		289	01
189.2	7.40	0.37	17.9	1.7	0.62	30			C	C		287	02
146.2	9.58	0.37	23.2	1.7	0.64	40			C	C		199	03
127.5	10.98	0.37	26.6	1.7	0.63	45			C	C		179	04

C Ratio
Rapporto
Untersetzung
Rapport de réduction
Relación

Transmitted torque
Momento torcente trasmesso
Mögliche Drehmomente
Couple de sortie
Par transmitido

Service factor
Fattore di servizio
Betriebsfaktor
Facteur de service
Factor de servicio

Output shaft diam.
Diam. albero uscita
Durchmesser abtriebswelle
Diametre arbre lent
Diametro eje de salida

Notes
Note
Anmerkungen
Note
Notas

fs

Type of load and starts per hour Tipo di carico e avviamenti per ora		Oper. hours per day Ore di funz. giorn.		
		3 h	10 h	24 h
Continuous or intermittent appl. with start / hour Applicazione cont. o interm. con n.ro operazioni/ora	Uniform / Uniforme	0.8	1	1.25
	Moderate / Moderato	1	1.25	1.5
	Heavy / Forte	1.25	1.5	1.75
Intermittent application with start / hour Applicazione intermittente con n.ro operazioni/ora	Uniform / Uniforme	1	1.25	1.5
	Moderate / Moderato	1.25	1.5	1.75
	Heavy / Forte	1.5	1.75	2.15

D Motor flange available
Flange disponibili
Erhältliche Motorflansche
Brides disponibles
Bridas disponibles

B) Mounting with reduction ring
Montaggio con boccia di riduzione
Reduzierhülsen
Montage avec douille de réduction
Montaje con casquillo de reducción

C) Motor flangeholes position/terminal box position
Posizione fori flangia/basetta motore
Bohrungsposition am Motorflansch/-socket
Position trous bride/barrette à bornes moteur
Posición agujeros brida / base motor

B) Available without reduction bushes
Disponibile anche senza boccia
Auch ohne Reduzierbüchse verfügbar
Disponible aussi sans douille de réduction
Disponible tambien sin casquillo

A	Select required torque (according to service factor)	Seleziona la coppia desiderata (comprensiva del fattore di servizio)	Max. Drehmoment in Bezug zum Betriebsfaktor	Sélectionner le couple souhaité (comprenant le facteur de service)	Seleccionar el par deseado (incluyendo el factor de servicio)
B	Select output speed	Seleziona la velocità in uscita	Ausgewählte Abtriebsdrehzahl	Sélectionner la vitesse de sortie	Seleccionar la velocidad de salida
C	On the same line of selected geared motor, you can find the gear ratio	Sulla riga corrispondente alla motorizzazione prescelta si può rilevare il rapporto di riduzione	Auf der gleichen Linie wie die ausgewählte Motorleistung steht auch die Getriebeuntersetzung	Sur la ligne correspondante à la motorisation pré-choisie on peut relever le rapport de réduction	En la línea correspondiente al motor preseleccionado es posible encontrar la relación de reducción
D	Select motor flange available (if requested)	Scegli la flangia disponibile (se richiesta)	Erhältliche Motorflansche (auf Anfrage)	Choisir la bride disponible (si elle est demandée)	Seleccionar la brida disponible (sobre pedido)



QUICK SELECTION / Selezione veloce The dynamic efficiency is **0.96** for all ratios **input speed (n₁) = 1400 min⁻¹**

Output Speed n ₂ [min ⁻¹]	Ratio i	Motor power P _{1M} [kW]	Output torque M _{2M} [Nm]	Service factor f.s.	Nominal power P _{1R} [kW]	Nominal torque M _{2R} [Nm]	Available B5 motor flanges		Available B14 motor flanges			Output Shaft 	Ratios code
							-B	-C	-O	-P	-Q		
290	4.83	0.37	12	2.6	0.95	30			C	C		289	01
189	7.40	0.37	18	1.7	0.62	30			C	C		287	02
146	9.58	0.37	23	1.7	0.64	40			C	C		199	03
128	10.98	0.37	27	1.7	0.63	45			C	C		179	04
107	13.07	0.37	32	1.4	0.53	45			C	C		159	05
95	14.66	0.37	35	1.3	0.47	45			C	C		197	06
89	15.79	0.37	38	1.2	0.44	45			C	C		139	07
83	16.81	0.37	41	1.1	0.41	45			C	C		177	08
70	20.00	0.37	48	1.0	0.37	48			C	C		157	09
64	21.93	0.37	53	0.9	0.35	50			C	C		109	10
58	24.18	0.25	39	1.3	0.32	50			C	C		137	11
48.2	29.04	0.25	47	1.1	0.26	50			C	C		99	12
41.7	33.57	0.18	42	1.2	0.23	50			C	C		107	13
36.2	38.67	0.18	48	1.0	0.20	50			C	C		79	14
31.5	44.44	0.18	55	0.9	0.17	50			C	C		97	15
23.7	59.18	0.12	48	1.0	0.13	50			C	C		77	16
19.9	70.24	0.09	45	1.1	0.11	50			C	C		67	17

Motor Flanges Available Flange Motore Disponibili B) Supplied with Reduction Bushing Fornito con Bussola di Riduzione B) Available on Request without reduction bushing Disponibile a Richiesta senza Bussola di Riduzione C) Motor Flange Holes Position Posizione Fori Flangia Motore

EN Unit **X22S** is supplied with synthetic oil for lifetime lubrication, no maintenance is necessary. See table 1 for lubrication and recommended quantity. In table 2 please see possible radial loads and axial loads on the gearbox.

I Il riduttore **X22S** viene fornito completo di olio sintetico per la lubrificazione permanente e non necessita di alcuna manutenzione. Vedi tab.1 per oli e quantità consigliati. In tab.2 sono presenti i carichi radiali e assiali applicabili al riduttore.

D Das Getriebe **X22S** ist mit synthetischem Öl gefüllt und ist lebensdauergeschmiert. In Tabelle 1 ist die Schmiermenge und das empfohlene Schmiermittel angegeben. In Tabelle 2 sind die zulässigen Radial- und Axialbelastungen des Getriebes aufgeführt.

F Le réducteur **X22S** est fourni complet avec de l'huile synthétique pour la lubrification permanente et ne nécessite aucun entretien. Voir tableau 1 concernant les huiles et les quantités conseillées. Les charges radiales et axiales applicables au réducteur sont précisées dans le tableau 2.

E El reductor tamaño **X22S** se suministra, lubricado de por vida con aceite sintético y no requieren mantenimiento alguna. Ver tabla 1, para cantidades y aceites recomendados. En la tabla 2, se encuentran las cargas radiales y axiales admitidas por el reductor.

Standard supplied	For these mounting position specify in the order or add oil Per queste posizioni specificare in fase d'ordine o aggiungere olio					
0.25 LT	0.25 LT	0.25 LT	0.25 LT	0.43 LT	0.31 LT	Ask
AGIP Telium VSF 320			SHELL Omala S4 WE 320			

For all details on lubrication and plugs check our website **tab. 1**
Per maggiori dettagli su lubrificazione e tappi olio vedi il nostro sito web

RADIAL AND AXIAL LOADS

Output shaft

Albero di uscita

$$F_{eq} = F_R \cdot \frac{42}{X+23}$$

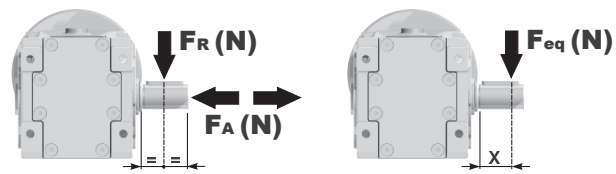

n ₂ [min ⁻¹]	FA	FR	n ₂ [min ⁻¹]	FA	FR	n ₂ [min ⁻¹]	FA	FR
400	360	1800	100	440	2200	25	440	2200
250	380	1900	75	440	2200	15	440	2200
150	420	2100	50	440	2200			

FR On request taper roller bearings to increase radial loads.
A richiesta cuscinetti a rulli conici per aumentare i carichi radiali.

Input shaft

albero in entrata

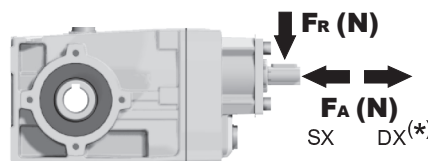

n ₁ [min ⁻¹]	FA	FR
1400	140	700
900	160	800
500	190	950

*Strong axial loads in the DX direction are not allowed.
Non sono consentiti forti carichi assiali con direzione DX

tab. 2

PX22SC... Basic Gearbox
Riduttore base

Gearbox weight
peso riduttore **3.70 kg**

M. flanges	Kit code	øF	A
63B5	K050.4.041	138	154.5
71B5	K050.4.042	160	152
56B14	KC40.4.049	80	152
63B14	K050.4.047	90	154.5
71B14	K050.4.045	105	152

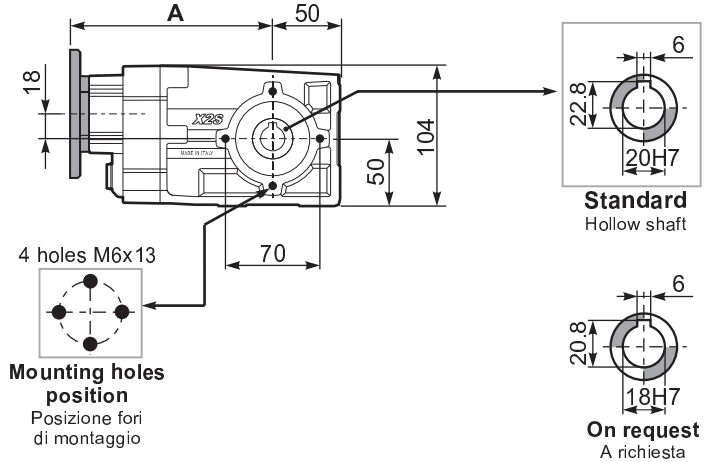
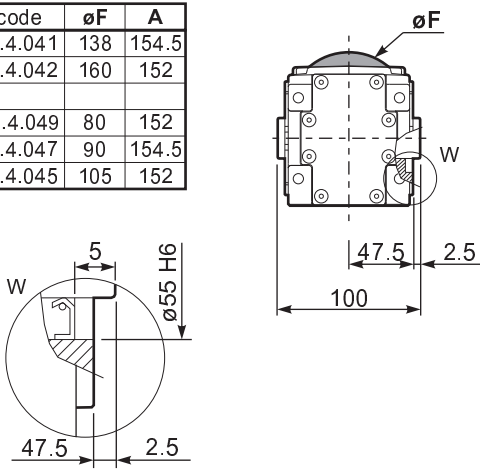

PX22S...FB.. Feet
Piedini

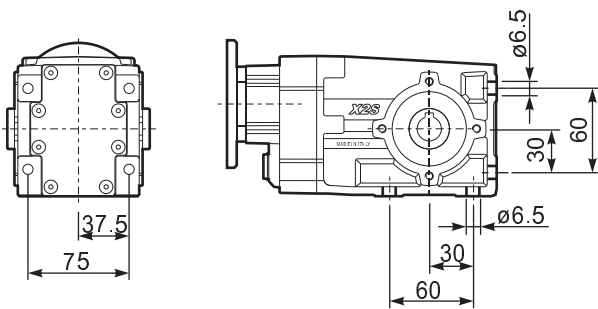

PX22S...-F0.. Output flange
Flangia uscita

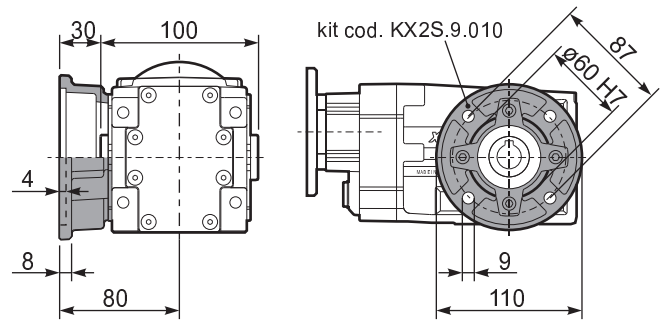

PX22S...-F1.. Output flange
Flangia uscita

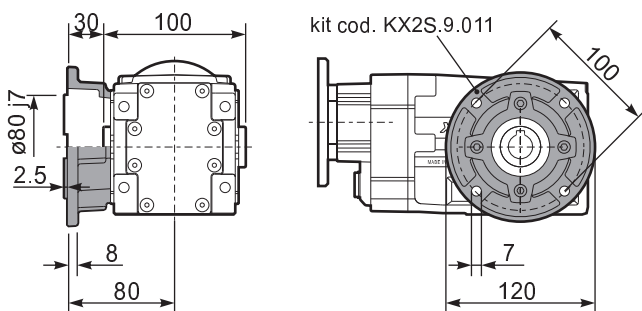

PX22S...BR.. Reaction Arm
Braccio di reazione

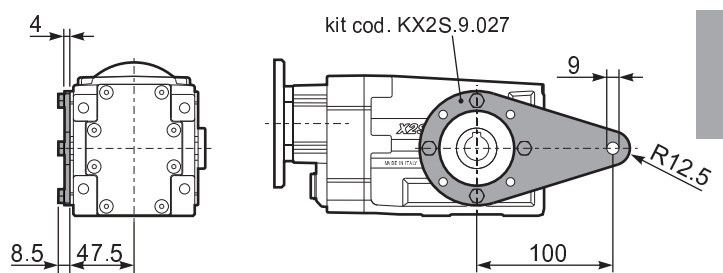

RX22S.. Input shaft
Albero in entrata

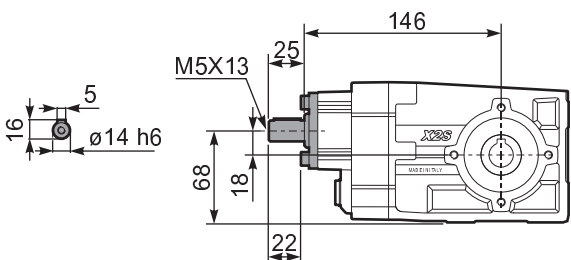

PX22SA.. Single output shaft
Albero semplice in uscita

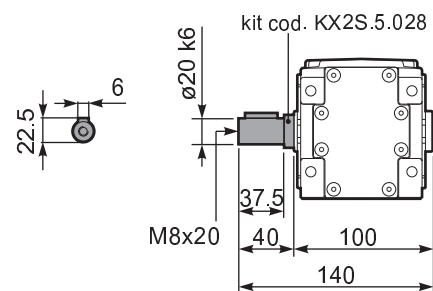

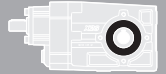

QUICK SELECTION / Selezione veloce The dynamic efficiency is **0.96** for all ratios **input speed (n₁) = 1400 min⁻¹**

Output Speed n ₂ [min ⁻¹]	Ratio i	Motor power P _{1M} [kW]	Output torque M _{2M} [Nm]	Service factor f.s.	Nominal power P _{1R} [kW]	Nominal torque M _{2R} [Nm]	Available B5 motor flanges				Available B14 motor flanges			Output Shaft 	Ratios code		
							-B	-C	-D	-E	-Q	-R	-T				
							63	71	80	90	71	80	90				
191	7.33	1.5	72	1.0	1.5	70	B				C	C		289	standard ø20	01	
125	11.22	1.1	80	1.1	1.2	85	B				C	C		287		02	
106	13.26	1.1	95	0.9	0.98	85	B				C	C		199		03	
91	15.37	1.1	110	0.8	0.89	90	B				C	C		179		04	
78	18.04	0.75	89	1.0	0.76	90	B				C	C		159		05	
69	20.30	0.75	100	0.9	0.68	90	B				C	C		197		06	
65	21.54	0.75	106	0.9	0.64	90	B				C	C		139		07	
59	23.53	0.55	85	1.1	0.58	90	B				C	C		177		08	
51	27.62	0.55	100	0.9	0.50	90	B				C	C		157		09	
47.6	29.40	0.55	106	0.8	0.47	90	B				C	C		109		On request	10
42.5	32.97	0.37	80	1.1	0.42	90	B				C	C		137		11	
36.5	38.37	0.37	93	1.0	0.36	90	B				C	C		99		12	
31.1	45.00	0.25	73	1.2	0.31	90	B				C	C		107		13	
27.6	50.67	0.25	83	1.1	0.27	90	B				C	C		79		14	
23.8	58.73	0.18	73	1.2	0.23	90	B				C	C		97		15	
18.1	77.55	0.18	97	0.9	0.18	90	B				C	C		77		16	

Motor Flanges Available Flange Motore Disponibili
 B) Supplied with Reduction Bushing Fornito con Bussola di Riduzione
 B) Available on Request without reduction bushing Disponibile a Richiesta senza Bussola di Riduzione
 C) Motor Flange Holes Position Posizione Fori Flangia Motore

EN Unit **X32S** is supplied with synthetic oil for lifetime lubrication, no maintenance is necessary. See table 1 for lubrication and recommended quantity. In table 2 please see possible radial loads and axial loads on the gearbox.

I Il riduttore **X32S** viene fornito completo di olio sintetico per la lubrificazione permanente e non necessita di alcuna manutenzione. Vedi tab.1 per oli e quantità consigliati. In tab.2 sono presenti i carichi radiali e assiali applicabili al riduttore.

D Das Getriebe **X32S** ist mit synthetischem Öl gefüllt und ist lebensdauergeschmiert. In Tabelle 1 ist die Schmiermenge und das empfohlene Schmiermittel angegeben. In Tabelle 2 sind die zulässigen Radial- und Axialbelastungen des Getriebes aufgeführt.

F Le réducteur **X32S** est fourni complet avec de l'huile synthétique pour la lubrification permanente et ne nécessite aucun entretien. Voir tableau 1 concernant les huiles et les quantités conseillées. Les charges radiales et axiales applicables au réducteur sont précisées dans le tableau 2.

E El reductor tamaño **X32S** se suministra, lubricado de por vida con aceite sintético y no requieren mantenimiento alguna. Ver tabla 1, para cantidades y aceites recomendados. En la tabla 2, se encuentran las cargas radiales y axiales admitidas por el reductor.

Standard supplied	For these mounting position specify in the order or add oil Per queste posizioni specificare in fase d'ordine o aggiungere olio					
0.40 LT	0.60 LT	0.40 LT	0.60 LT	0.85 LT	0.60 LT	Ask
AGIP Telium VSF 320				SHELL Omala S4 WE 320		

For all details on lubrication and plugs check our website **tab. 1**
Per maggiori dettagli su lubrificazione e tappi olio vedi il nostro sito web

RADIAL AND AXIAL LOADS

Output shaft
Albero di uscita

$$F_{eq} = F_R \cdot \frac{47.5}{X+28.5}$$

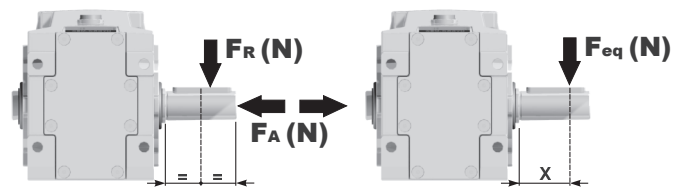

n ₂ [min ⁻¹]	FA	FR	n ₂ [min ⁻¹]	FA	FR	n ₂ [min ⁻¹]	FA	FR
250	400	2000	75	560	2800	15	560	2800
150	450	2250	50	560	2800			
100	500	2500	25	560	2800			

FR On request taper roller bearings to increase radial loads.
A richiesta cuscinetti a rulli conici per aumentare i carichi radiali.

Input shaft
albero in entrata

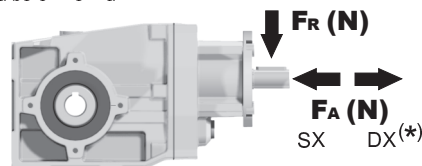

n ₁ [min ⁻¹]	FA	FR
1400	240	1200
900	280	1400
500	340	1700

***Strong axial loads in the DX direction are not allowed.**
Non sono consentiti forti carichi assiali con direzione DX

tab. 2

PX32SC... Basic Gearbox
Riduttore base

Gearbox weight
peso riduttore **6.30 kg**

M. flanges	Kit code	øF	A
63B5	K063.4.041	140	184
71B5	K063.4.042	160	182
80/90B5	K063.4.043	200	184
71B14	K063.4.047	105	182
80B14	K063.4.046	120	184
90B14	K063.4.041	140	184

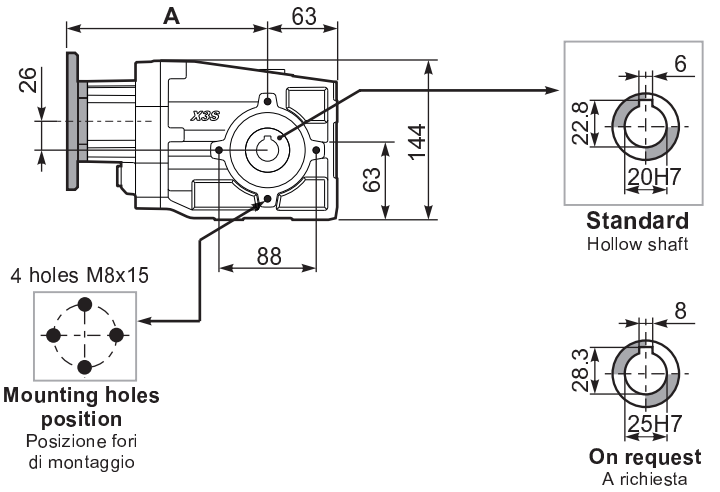
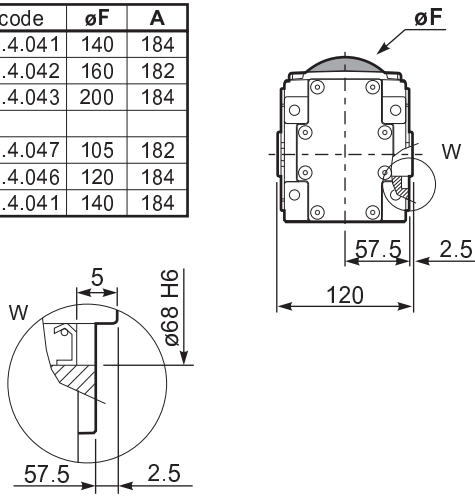

4 holes M8x15
Mounting holes position
Posizione fori di montaggio

PX32S...FB.. Feet
Piedini

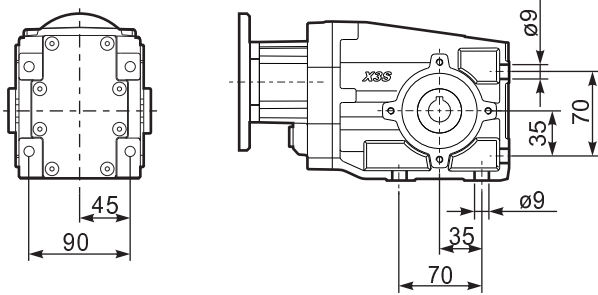

PX32S...-F1.. Output flange
Flangia uscita

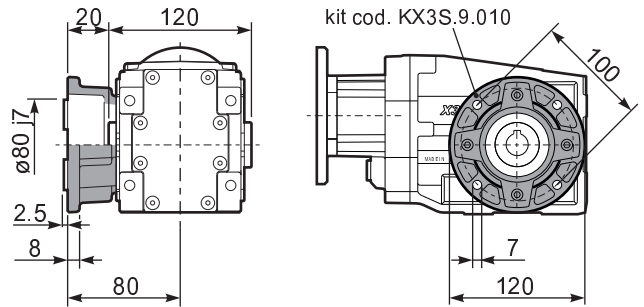

PX32S...-F2.. Output flange
Flangia uscita

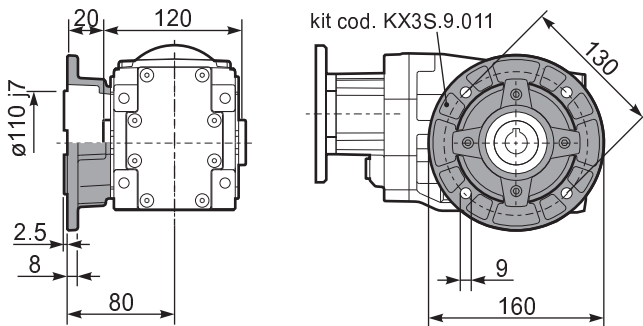

PX32S...BR.. Reaction Arm
Braccio di reazione

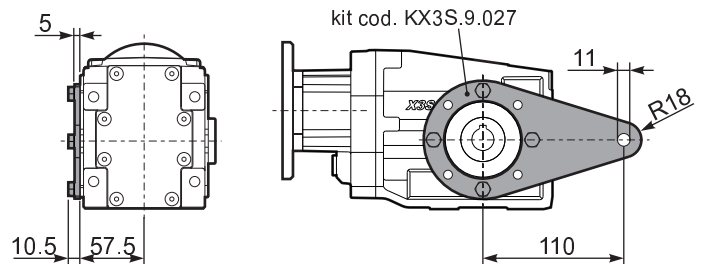

RX32S... Input shaft
Albero in entrata

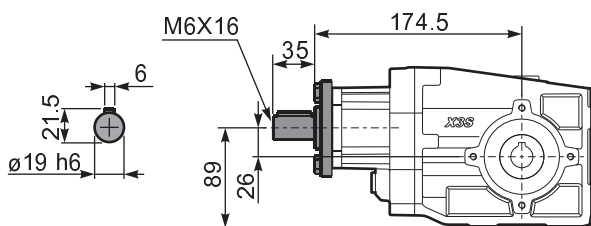

PX32SA.. Single output shaft
Albero semplice in uscita

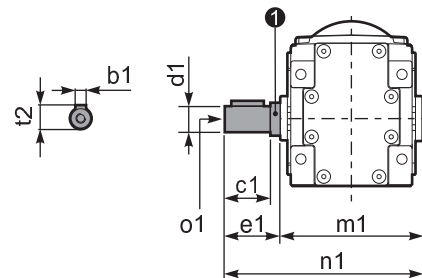

d1	b1	c1	e1	m1	n1	t2	o1	1 kit code
ø20 ^{-0.005/-0.020}	6	37.5	40	120	160	22.5	M8x20	KX2S.5.028
ø25 ^{-0.005/-0.020}	8	60	63.2	126.8	190	28	M8x20	K063.5.028



QUICK SELECTION / Selezione veloce The dynamic efficiency is **0.94** for all ratios **input speed (n₁) = 1400 min⁻¹**

Output Speed n ₂ [min ⁻¹]	Ratio i	Motor power P _{1M} [kW]	Output torque M _{2M} [Nm]	Service factor f.s.	Nominal power P _{1R} [kW]	Nominal torque M _{2R} [Nm]	Available B5 motor flanges		Available B14 motor flanges			Output Shaft 	Ratios code
							-B	-C	-O	-P	-Q		
							63	71	56	63	71		
38.7	36.17	0.37	86	1.2	0.43	100			C	C		17179	02
31.7	44.21	0.37	105	1.0	0.35	100			C	C		19139	03
27.6	50.68	0.25	81	1.2	0.31	100			C	C		17139	04
25.3	55.36	0.25	89	1.1	0.28	100			C	C		17177	05
23.2	60.31	0.25	96	1.0	0.26	100			C	C		15139	06
21.2	65.88	0.25	105	0.9	0.24	100			C	C		15177	07
19.4	72.25	0.18	88	1.1	0.22	100			C	C		10179	08
17.6	79.64	0.18	97	1.0	0.20	100			C	C	standard ø20	13177	09
15.2	92.31	0.18	113	0.9	0.17	100			C	C		15137	10
14.6	95.65	0.18	117	0.9	0.16	100			C	C		9179	11
13.8	101.23	0.12	80	1.2	0.15	100			C	C	ø25	10139	12
11.0	127.37	0.12	101	1.0	0.12	100			C	C	On request	7179	13
9.3	151.16	0.09	95	1.0	0.10	100			C	C		6179	14
7.8	178.46	0.09	113	0.9	0.09	100			C	C		7139	15
6.6	211.79	0.06	88	1.1	0.07	100			C	C		6139	16
6.1	231.37	0.06	96	1.0	0.07	100			C	C		6177	17
5.1	273.16	0.06	113	0.9	0.06	100			C	C		7137	18
4.3	324.18	0.06	134	0.7	0.05	100			C	C		6137	19

Motor Flanges Available Flange Motore Disponibili B) Supplied with Reduction Bushing Fornito con Bussola di Riduzione B) Available on Request without reduction bushing Disponibile a Richiesta senza Bussola di Riduzione C) Motor Flange Holes Position Posizione Fori Flangia Motore

EN Unit **X33S** is supplied with synthetic oil for lifetime lubrication, no maintenance is necessary. See table 1 for lubrication and recommended quantity. In table 2 please see possible radial loads and axial loads on the gearbox.

I Il riduttore **X33S** viene fornito completo di olio sintetico per la lubrificazione permanente e non necessita di alcuna manutenzione. Vedi tab.1 per oli e quantità consigliati. In tab.2 sono presenti i carichi radiali e assiali applicabili al riduttore.

D Das Getriebe **X33S** ist mit synthetischem Öl gefüllt und ist lebensdauergeschmiert. In Tabelle 1 ist die Schmiermenge und das empfohlene Schmiermittel angegeben. In Tabelle 2 sind die zulässigen Radial - und Axialbelastungen des Getriebes aufgeführt.

F Le réducteur **X33S** est fourni complet avec de l'huile synthétique pour la lubrification permanente et ne nécessite aucun entretien. Voir tableau 1 concernant les huiles et les quantités conseillées. Les charges radiales et axiales applicables au réducteur sont précisées dans le tableau 2.

E El reductor tamaño **X33S** se suministra, lubricado de por vida con aceite sintético y no requieren mantenimiento alguna. Ver tabla 1, para cantidades y aceites recomendados. En la tabla 2, se encuentran las cargas radiales y axiales admitidas por el reductor.

Standard supplied	For these mounting position specify in the order or add oil Per queste posizioni specificare in fase d'ordine o aggiungere olio					
0.70 LT	0.65 LT	0.40 LT	0.65 LT	0.95 LT	0.65 LT	Ask
AGIP Telium VSF 320				SHELL Omala S4 WE 320		

For all details on lubrication and plugs check our website **tab. 1**
Per maggiori dettagli su lubrificazione e tappi olio vedi il nostro sito web

RADIAL AND AXIAL LOADS

Output shaft
Albero di uscita

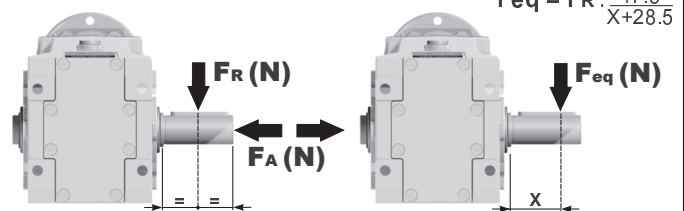

n ₂ [min ⁻¹]	FA	FR	n ₂ [min ⁻¹]	FA	FR	n ₂ [min ⁻¹]	FA	FR
250	400	2000	75	560	2800	15	560	2800
150	450	2250	50	560	2800			
100	500	2500	25	560	2800			

FR On request taper roller bearings to increase radial loads.
A richiesta cuscinetti a rulli conici per aumentare i carichi radiali.

Input shaft
albero in entrata

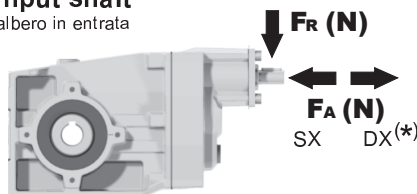

n ₁ [min ⁻¹]	FA	FR
1400	140	700
900	160	800
500	190	950

*Strong axial loads in the DX direction are not allowed.
Non sono consentiti forti carichi assiali con direzione DX

tab. 2

PX33SC... Basic Gearbox
Riduttore base

Gearbox weight
peso riduttore **6.55 kg**

M. flanges	Kit code	øF	A
63B5	K050.4.041	138	189.5
71B5	K050.4.042	160	187
56B14	KC40.4.049	80	187
63B14	K050.4.047	90	189.5
71B14	K050.4.045	105	187

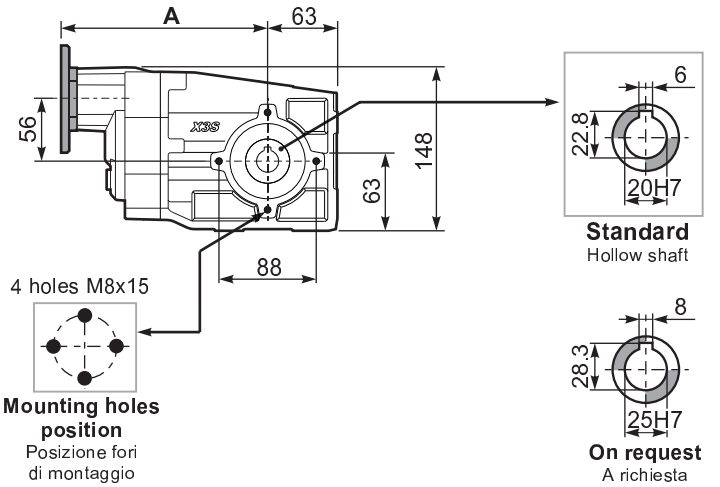
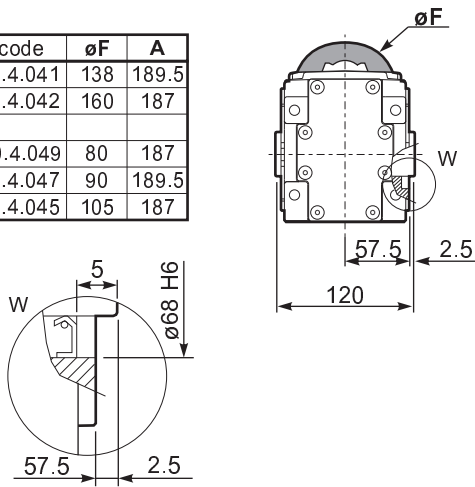

PX33S...FB.. Feet
Piedini

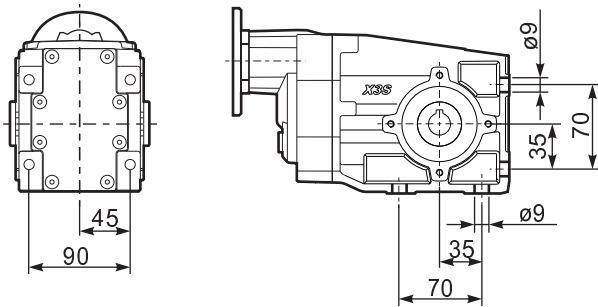

PX33S...-F1.. Output flange
Flangia uscita

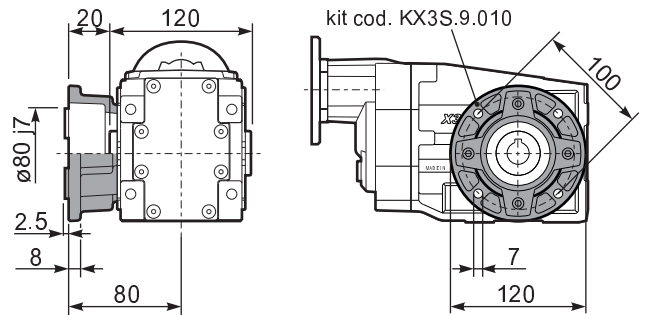

PX33S...-F2.. Output flange
Flangia uscita

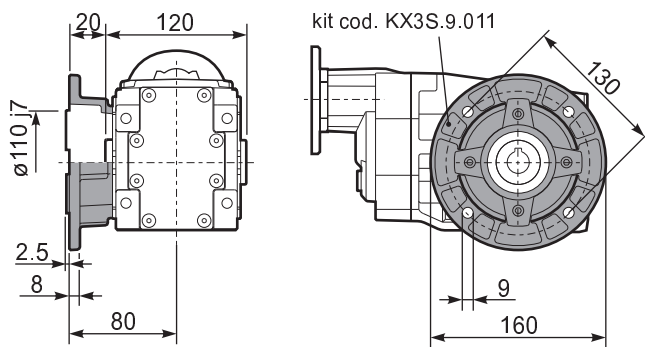

PX33S...BR.. Reaction Arm
Braccio di reazione

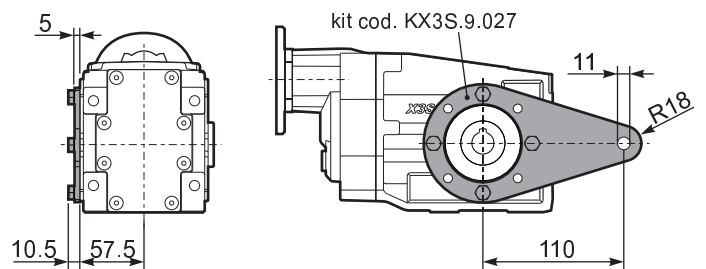

RX33S... Input shaft
Albero in entrata

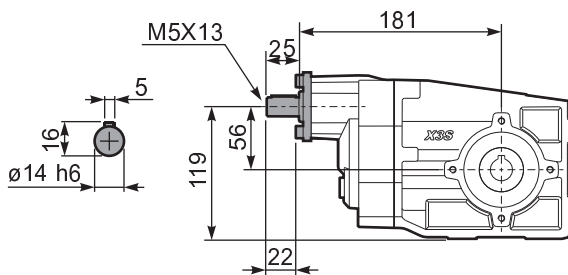

PX33SA.. Single output shaft
Albero semplice in uscita

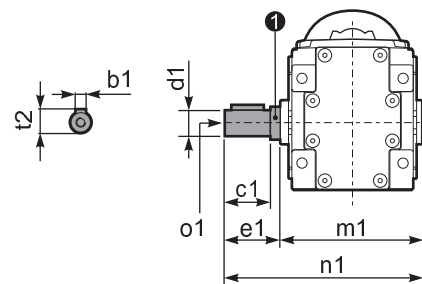

d1	b1	c1	e1	m1	n1	t2	o1	1 kit code
ø20 ^{-0.005/-0.020}	6	37.5	40	120	160	22.5	M8x20	KX2S.5.028
ø25 ^{-0.005/-0.020}	8	60	63.2	126.8	190	28	M8x20	K063.5.028

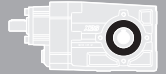

QUICK SELECTION / Selezione veloce The dynamic efficiency is **0.96** for all ratios **input speed (n₁) = 1400 min⁻¹**

Output Speed n ₂ [min ⁻¹]	Ratio i	Motor power P _{1M} [kW]	Output torque M _{2M} [Nm]	Service factor f.s.	Nominal power P _{1R} [kW]	Nominal torque M _{2R} [Nm]	Available B5 motor flanges					Available B14 motor flanges				Output Shaft 	Ratios code
							-B	-C	-D	-E	-F	-Q	-R	-T	-U		
							63	71	80	90	100	112	71	80	90		
192	7.29	2.2	104	0.9	2.0	95	B					C	C			2811	01
125	11.20	2.2	159	0.9	2.0	150	B					C	C			288	02
106	13.18	1.5	129	1.2	1.7	150	B					C	C			1911	03
92	15.27	1.1	109	1.4	1.5	150	B					C	C			1711	04
78	17.93	1.1	128	1.2	1.3	150	B					C	C			1511	05
69	20.25	1.1	145	1.0	1.1	150	B					C	C			198	06
65	21.40	1.1	153	1.0	1.1	150	B					C	C			1311	07
60	23.47	0.75	115	1.3	0.98	150	B					C	C			178	08
51	27.55	0.75	135	1.1	0.83	150	B					C	C			158	09
47.9	29.21	0.75	143	1.0	0.78	150	B					C	C			1011	10
42.6	32.88	0.75	161	0.9	0.70	150	B					C	C			138	11
36.7	38.12	0.55	138	1.1	0.60	150	B					C	C			911	12
31.2	44.89	0.55	163	0.9	0.51	150	B					C	C			108	13
27.8	50.34	0.37	122	1.1	0.40	131	B					C	C			711	14
23.9	58.58	0.37	142	1.1	0.39	150	B					C	C			98	15
18.1	77.36	0.25	126	1.2	0.30	150	B					C	C			78	16

Motor Flanges Available Flange Motore Disponibili B) Supplied with Reduction Bushing Fornito con Bussola di Riduzione B) Available on Request without reduction bushing Disponibile a Richiesta senza Bussola di Riduzione C) Motor Flange Holes Position Posizione Fori Flangia Motore

EN Unit **X42A** is supplied with synthetic oil for lifetime lubrication, no maintenance is necessary. See table 1 for lubrication and recommended quantity. In table 2 please see possible radial loads and axial loads on the gearbox.

I Il riduttore **X42A** viene fornito completo di olio sintetico per la lubrificazione permanente e non necessita di alcuna manutenzione. Vedi tab.1 per oli e quantità consigliati. In tab.2 sono presenti i carichi radiali e assiali applicabili al riduttore.

D Das Getriebe **X42A** ist mit synthetischem Öl gefüllt und ist lebensdauergeschmiert. In Tabelle 1 ist die Schmiermenge und das empfohlene Schmiermittel angegeben. In Tabelle 2 sind die zulässigen Radial- und Axialbelastungen des Getriebes aufgeführt.

F Le réducteur **X42A** est fourni complet avec de l'huile synthétique pour la lubrification permanente et ne nécessite aucun entretien. Voir tableau 1 concernant les huiles et les quantités conseillées. Les charges radiales et axiales applicables au réducteur sont précisées dans le tableau 2.

E El reductor tamaño **X42A** se suministra, lubricado de por vida con aceite sintético y no requieren mantenimiento alguna. Ver tabla 1, para cantidades y aceites recomendados. En la tabla 2, se encuentran las cargas radiales y axiales admitidas por el reductor.

Standard supplied	For these mounting position specify in the order or add oil Per queste posizioni specificare in fase d'ordine o aggiungere olio					
B3	B6	B7	B8	V5	V6	V8
0.60 LT	0.75 LT	0.50 LT	0.70 LT	1.10 LT	0.60 LT	Ask
AGIP Telium VSF 320				SHELL Omala S4 WE 320		

For all details on lubrication and plugs check our website **tab. 1**
Per maggiori dettagli su lubrificazione e tappi olio vedi il nostro sito web

RADIAL AND AXIAL LOADS

Output shaft

Albero di uscita

$$F_{eq} = F_R \cdot \frac{54}{X+28}$$

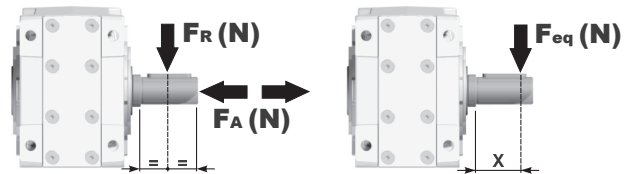

n ₂ [min ⁻¹]	FA	FR	n ₂ [min ⁻¹]	FA	FR	n ₂ [min ⁻¹]	FA	FR
250	500	2500	75	800	4000	15	960	4800
150	600	3000	50	960	4800			
100	700	3500	25	960	4800			

FR On request taper roller bearings to increase radial loads.
A richiesta cuscinetti a rulli conici per aumentare i carichi radiali.

Input shaft

albero in entrata

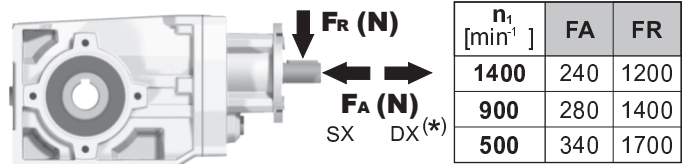

n ₁ [min ⁻¹]	FA	FR
1400	240	1200
900	280	1400
500	340	1700

***Strong axial loads in the DX direction are not allowed.**
Non sono consentiti forti carichi assiali con direzione DX

tab. 2

PX42AC... Basic Gearbox
Riduttore base

Gearbox weight **7.82 kg**
peso riduttore

M. flanges	Kit code	øF	A
63B5	K063.4.041	140	199.5
71B5	K063.4.042	160	197.5
80/90B5	K063.4.043	200	199.5
100/112B5	KC40.4.043	250	214.3
71B14	K063.4.047	105	197.5
80B14	K063.4.046	120	199.5
90B14	K063.4.041	140	199.5
100/112B14	KC40.4.041	160	214.3

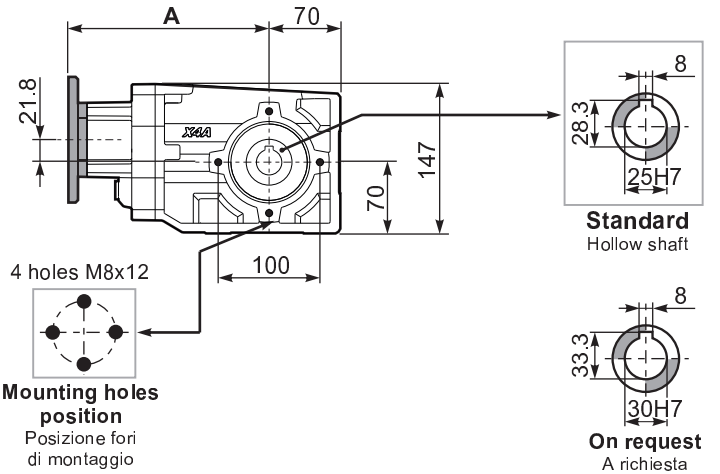
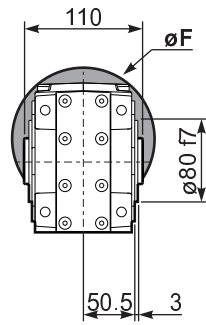

PX42A...FB.. Feet
Piedini

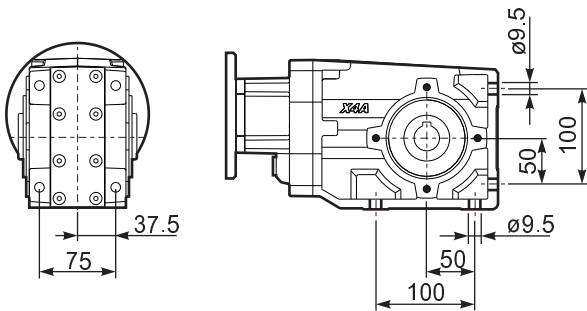

PX42A...-F2.. Output flange
Flangia uscita

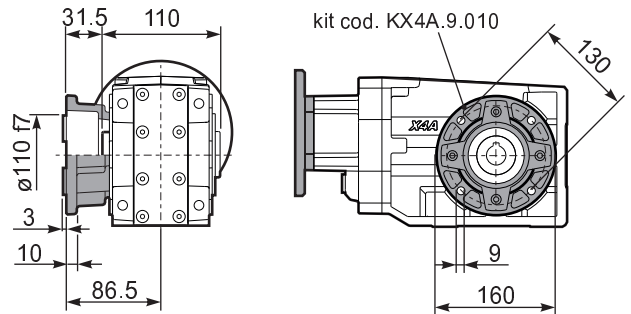

PX42A...-F3.. Output flange
Flangia uscita

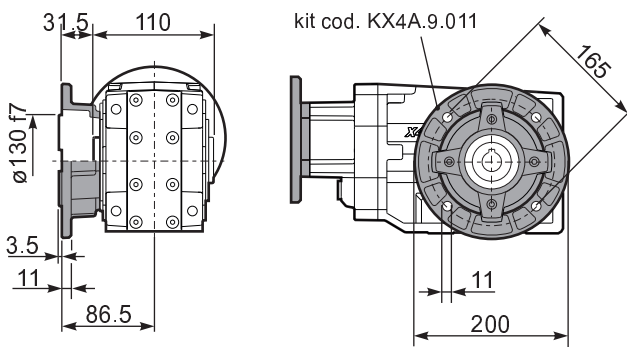

PX42A...-F4.. Output flange
Flangia uscita

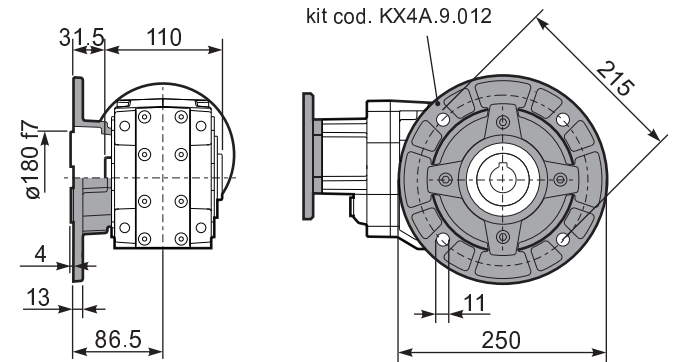

RX42A... Input shaft
Albero in entrata

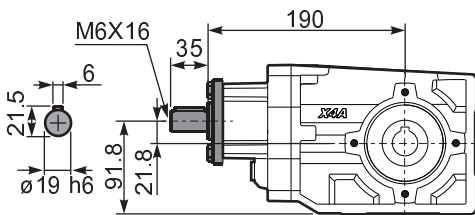

PX42A...BR.. Reaction Arm
Braccio di reazione

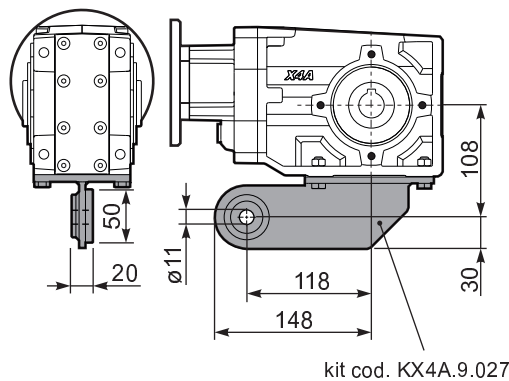

PX42A... Single output shaft
Albero semplice in uscita

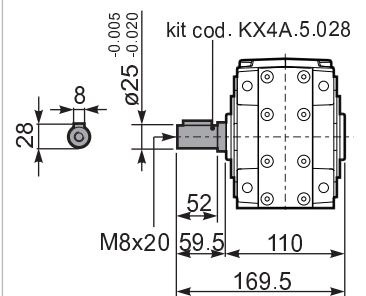



QUICK SELECTION / Selezione veloce The dynamic efficiency is **0.94** for all ratios **input speed (n₁) = 1400 min⁻¹**

Output Speed n ₂ [min ⁻¹]	Ratio i	Motor power P _{1M} [kW]	Output torque M _{2M} [Nm]	Service factor f.s.	Nominal power P _{1R} [kW]	Nominal torque M _{2R} [Nm]	Available B5 motor flanges		Available B14 motor flanges			Output Shaft 	Ratios code
							-B	-C	-O	-P	-Q		
							63	71	56	63	71		
27.8	50.35	0.37	119	1.3	0.46	150			C	C		171311	01
25.4	55.22	0.37	131	1.1	0.42	150			C	C		17178	02
23.4	59.92	0.37	142	1.1	0.39	150			C	C		151311	03
21.3	65.72	0.37	156	1.0	0.36	150			C	C		15178	04
19.5	71.78	0.25	115	1.3	0.33	150			C	C		101711	05
17.6	79.44	0.25	127	1.2	0.29	150			C	C		13178	06
15.2	92.08	0.25	147	1.0	0.25	150			C	C		15138	07
14.7	95.03	0.25	152	1.0	0.25	150			C	C		91711	08
11.1	126.55	0.18	155	1.0	0.20	160			C	C		71711	09
10.5	133.15	0.18	163	1.0	0.19	160			C	C		91311	10
9.3	150.18	0.12	119	1.3	0.17	160			C	C		61711	11
7.9	177.30	0.12	140	1.1	0.14	160			C	C		71311	12
6.7	210.42	0.09	133	1.2	0.12	160			C	C		61311	13
6.1	230.79	0.09	146	1.1	0.11	160			C	C		6178	14
5.1	272.47	0.06	113	1.4	0.09	160			C	C		7138	15
4.3	323.37	0.06	134	1.2	0.08	160			C	C		6138	16

Motor Flanges Available Flange Motore Disponibili
 B) Supplied with Reduction Bushing Fornito con Bussola di Riduzione
 B) Available on Request without reduction bushing Disponibile a Richiesta senza Bussola di Riduzione
 C) Motor Flange Holes Position Posizione Fori Flangia Motore

EN Unit **X43A** is supplied with synthetic oil for lifetime lubrication, no maintenance is necessary. See table 1 for lubrication and recommended quantity. In table 2 please see possible radial loads and axial loads on the gearbox.

I Il riduttore **X43A** viene fornito completo di olio sintetico per la lubrificazione permanente e non necessita di alcuna manutenzione. Vedi tab.1 per oli e quantità consigliati. In tab.2 sono presenti i carichi radiali e assiali applicabili al riduttore.

D Das Getriebe **X43A** ist mit synthetischem Öl gefüllt und ist lebensdauergeschmiert. In Tabelle 1 ist die Schmiermenge und das empfohlene Schmiermittel angegeben. In Tabelle 2 sind die zulässigen Radial- und Axialbelastungen des Getriebes aufgeführt.

F Le réducteur **X43A** est fourni complet avec de l'huile synthétique pour la lubrification permanente et ne nécessite aucun entretien. Voir tableau 1 concernant les huiles et les quantités conseillées. Les charges radiales et axiales applicables au réducteur sont précisées dans le tableau 2.

E El reductor tamaño **X43A** se suministra, lubricado de por vida con aceite sintético y no requieren mantenimiento alguna. Ver tabla 1, para cantidades y aceites recomendados. En la tabla 2, se encuentran las cargas radiales y axiales admitidas por el reductor.

Standard supplied	For these mounting position specify in the order or add oil Per queste posizioni specificare in fase d'ordine o aggiungere olio					
B3	B6	B7	B8	V5	V6	V8
0.80 LT	0.80 LT	0.60 LT	0.80 LT	1.20 LT	0.70 LT	Ask
AGIP Telium VSF 320			SHELL Omala S4 WE 320			

For all details on lubrication and plugs check our website **tab. 1**
Per maggiori dettagli su lubrificazione e tappi olio vedi il nostro sito web

RADIAL AND AXIAL LOADS

Output shaft

Albero di uscita

$$F_{eq} = F_R \cdot \frac{54}{X+28}$$

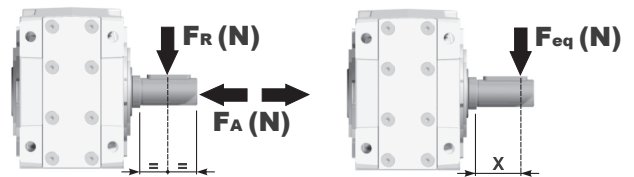

n ₂ [min ⁻¹]	FA	FR	n ₂ [min ⁻¹]	FA	FR	n ₂ [min ⁻¹]	FA	FR
250	500	2500	75	800	4000	15	960	4800
150	600	3000	50	960	4800			
100	700	3500	25	960	4800			

FR On request taper roller bearings to increase radial loads.
A richiesta cuscinetti a rulli conici per aumentare i carichi radiali.

Input shaft

albero in entrata

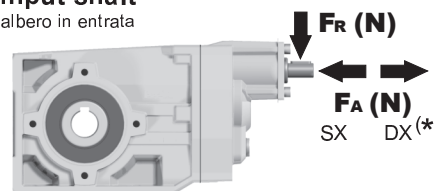

n ₁ [min ⁻¹]	FA [N]	FR [N]
1400	140	700
900	160	800
500	190	950

*Strong axial loads in the DX direction are not allowed.
Non sono consentiti forti carichi assiali con direzione DX

PX43AC... Basic Gearbox
Riduttore base

Gearbox weight **7.93 kg**
peso riduttore

M. flanges	Kit code	øF	A
63B5	K050.4.041	138	205
71B5	K050.4.042	160	202.5
56B14	KC40.4.049	80	202.5
63B14	K050.4.047	90	205
71B14	K050.4.045	105	202.5

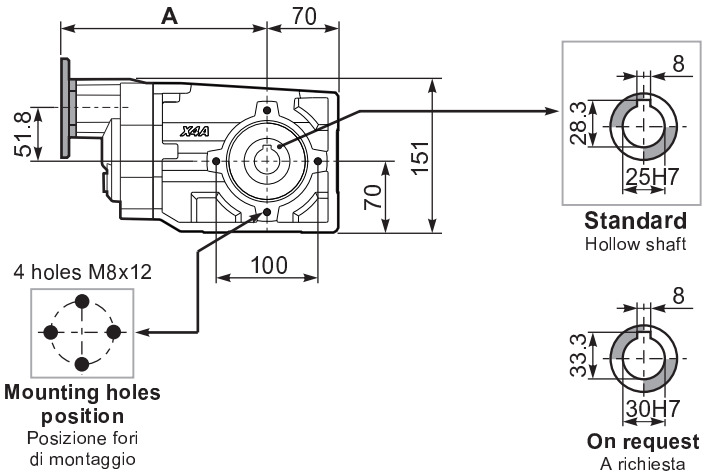
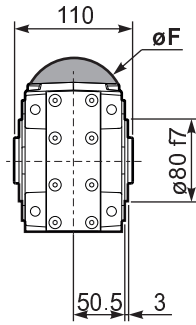

PX43A...FB Feet
Piedini

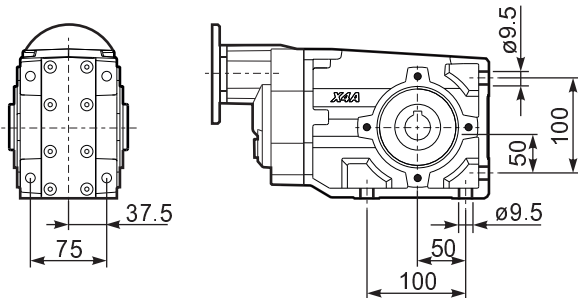

PX43A...-F2 Output flange
Flangia uscita

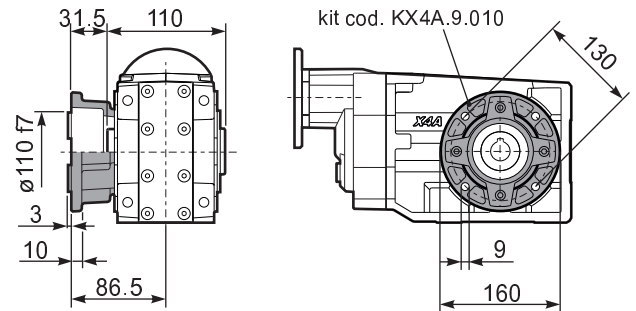

PX43A...-F3 Output flange
Flangia uscita

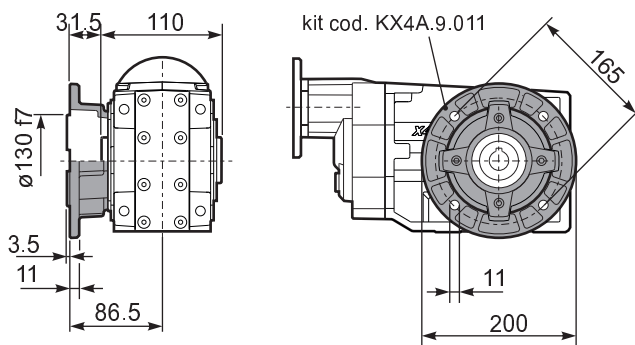

PX43A...-F4 Output flange
Flangia uscita

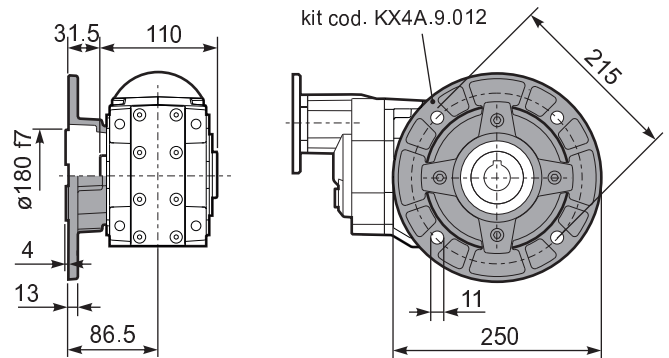

RX43A... Input shaft
Albero in entrata

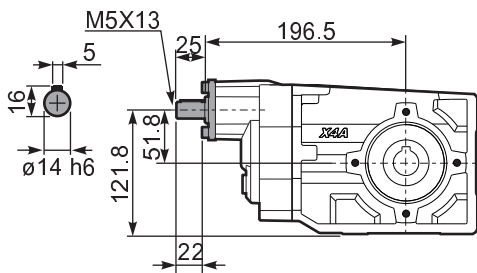

PX43A...BR Reaction Arm
Braccio di reazione

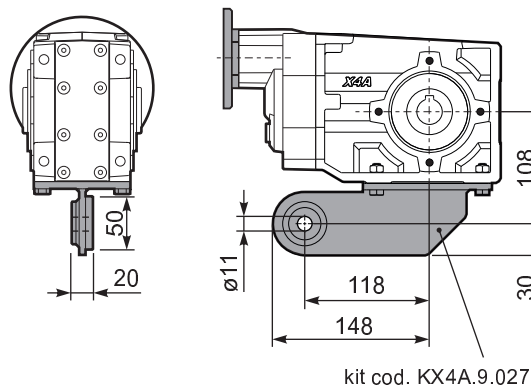

PX43AA Single output shaft
Albero semplice in uscita

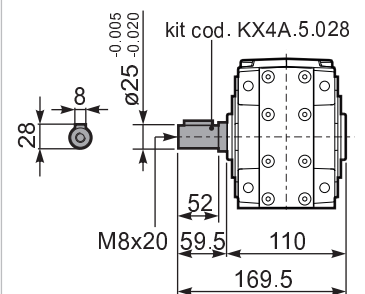

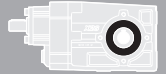

QUICK SELECTION / Selezione veloce The dynamic efficiency is **0.96** for all ratios **input speed (n₁) = 1400 min⁻¹**

Output Speed n ₂ [min ⁻¹]	Ratio i	Motor power P _{1M} [kW]	Output torque M _{2M} [Nm]	Service factor f.s.	Nominal power P _{1R} [kW]	Nominal torque M _{2R} [Nm]	Available B5 motor flanges				Available B14 motor flanges			Output Shaft 	Ratios code
							-C	-D	-E	-F	-R	-T	-U		
							71	80	90	100 112	80	90	100 112		
232	6.03	3	116	1.2	3.4	135	B							3011	01
151	9.26	3	179	0.9	2.6	155	B							308	02
123	11.36	3	219	1.0	3.1	230	B							2011	03
91	15.36	2.2	218	1.1	2.5	250	B							1611	04
80	17.46	2.2	248	1.0	2.2	250	B							208	05
70	19.97	2.2	284	0.9	1.9	250	B							1311	06
59	23.60	1.5	231	1.1	1.6	250	B							168	07
57	24.45	1.5	239	1.0	1.6	250	B							1111	08
45.6	30.69	1.1	220	1.1	1.2	250	B							138	09
39.6	35.35	1.1	253	1.0	1.1	250	B							811	10
37.3	37.57	1.1	269	0.9	1.0	250	B							118	11
28.8	48.68	0.75	239	1.0	0.78	250	B							611	12
25.8	54.33	0.75	267	0.9	0.70	250	B							88	13
18.7	74.81	0.37	181	1.2	0.43	210	B							68	14

A) Motor Flanges Available
Flange Motore Disponibili

B) Supplied with Reduction Bushing
Fornito con Bussola di Riduzione

B) Available on Request without reduction bushing
Disponibile a Richiesta senza Bussola di Riduzione

C) Motor Flange Holes Position
Posizione Fori Flangia Motore

EN Unit **X52A** is supplied with synthetic oil for lifetime lubrication, no maintenance is necessary. See table 1 for lubrication and recommended quantity. In table 2 please see possible radial loads and axial loads on the gearbox.

I Il riduttore **X52A** viene fornito completo di olio sintetico per la lubrificazione permanente e non necessita di alcuna manutenzione. Vedi tab.1 per oli e quantità consigliati. In tab.2 sono presenti i carichi radiali e assiali applicabili al riduttore.

D Das Getriebe **X52A** ist mit synthetischem Öl gefüllt und ist lebensdauergeschmiert. In Tabelle 1 ist die Schmiermenge und das empfohlene Schmiermittel angegeben. In Tabelle 2 sind die zulässigen Radial - und Axialbelastungen des Getriebes aufgeführt.

F Le réducteur **X52A** est fourni complet avec de l'huile synthétique pour la lubrification permanente et ne nécessite aucun entretien. Voir tableau 1 concernant les huiles et les quantités conseillées. Les charges radiales et axiales applicables au réducteur sont précisées dans le tableau 2.

E El reductor tamaño **X52A** se suministra, lubricado de por vida con aceite sintético y no requieren mantenimiento alguna. Ver tabla 1, para cantidades y aceites recomendados. En la tabla 2, se encuentran las cargas radiales y axiales admitidas por el reductor.

Standard supplied	For these mounting position specify in the order or add oil Per queste posizioni specificare in fase d'ordine o aggiungere olio						
B3	B6	B7	B8	V5	V6	V8	V8
0.90 LT	1.50LT	0.75 LT	1.40 LT	1.95 LT	1.15 LT	1.15 LT	Ask
AGIP Telium VSF 320				SHELL Omala S4 WE 320			

For all details on lubrication and plugs check our website **tab. 1**
Per maggiori dettagli su lubrificazione e tappi olio vedi il nostro sito web

RADIAL AND AXIAL LOADS

Output shaft
Albero di uscita

$$F_{eq} = F_R \cdot \frac{61.5}{X+31}$$

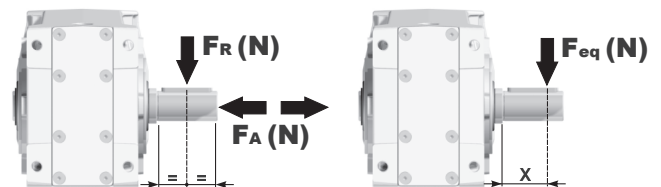

n ₂ [min ⁻¹]	FA	FR	n ₂ [min ⁻¹]	FA	FR	n ₂ [min ⁻¹]	FA	FR
250	600	3000	75	820	4100	15	1660	8300
150	700	3500	50	960	4800			
100	800	4000	25	1350	6750			

F_R On request taper roller bearings to increase radial loads.
A richiesta cuscinetti a rulli conici per aumentare i carichi radiali.

Input shaft
albero in entrata

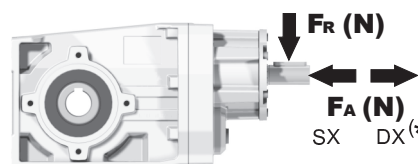

n ₁ [min ⁻¹]	FA	FR
1400	450	2250
900	500	2500
500	600	3000

*Strong axial loads in the DX direction are not allowed.
Non sono consentiti forti carichi assiali con direzione DX

tab. 2

PX52AC... Basic Gearbox
Riduttore base

Gearbox weight **12.80 kg**
peso riduttore

M. flanges	Kit code	øF	A
71B5	K023.4.041	160	234
80/90B5	K023.4.042	200	236
100/112B5	K023.4.043	250	245
80B14	K085.4.046	120	236
90B14	K085.4.045	140	236
100/112B14	K085.4.047	160	245

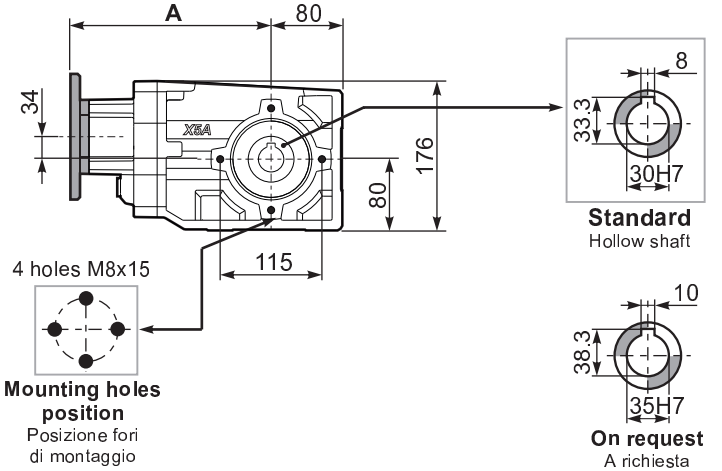
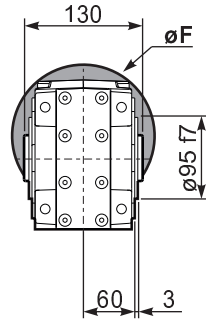

PX52A...FB.. Feet
Piedini

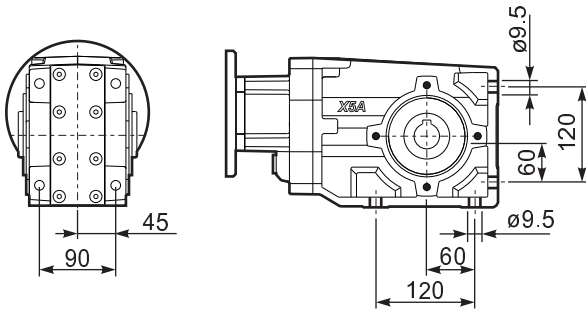

PX52A...-F2.. Output flange
Flangia uscita

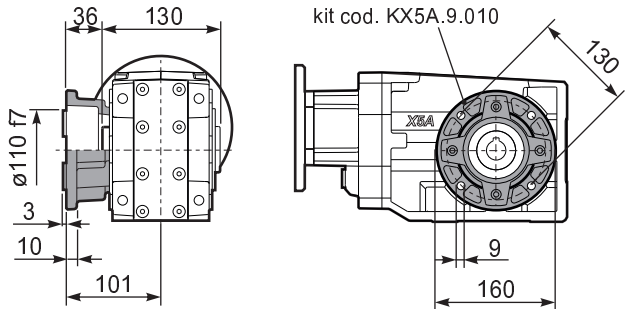

PX52A...-F3.. Output flange
Flangia uscita

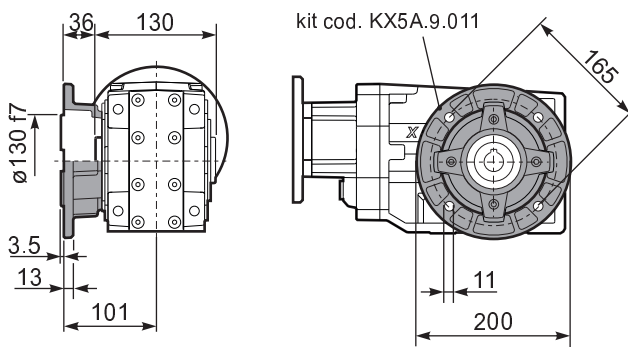

PX52A...-F4.. Output flange
Flangia uscita

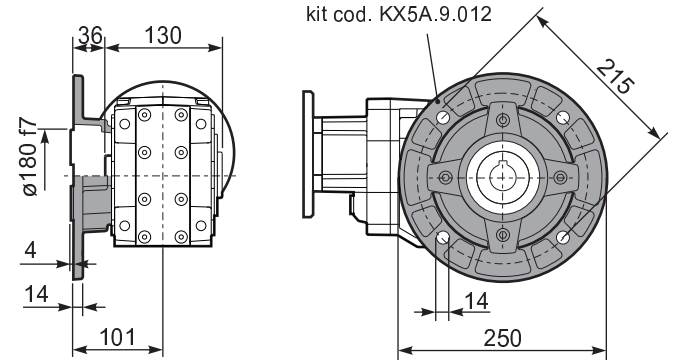

RX52A... Input shaft
Albero in entrata

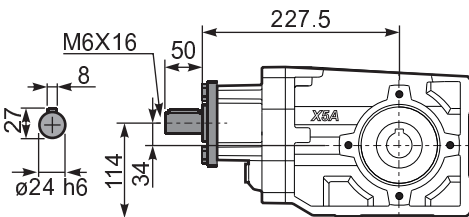

PX52A...BR.. Reaction Arm
Braccio di reazione

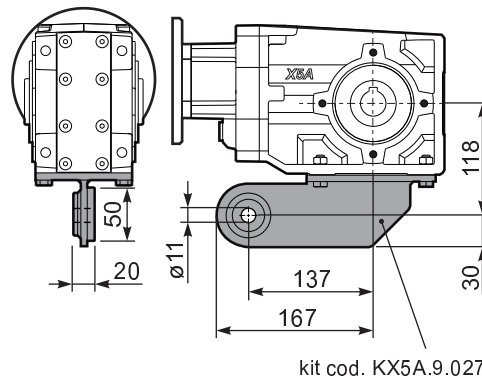

PX52AA.. Single output shaft
Albero semplice in uscita

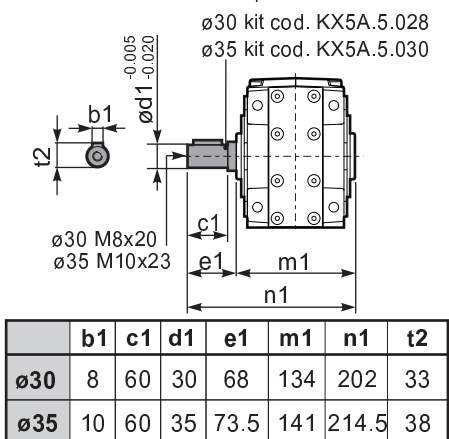

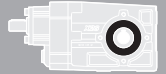

QUICK SELECTION / Selezione veloce The dynamic efficiency is **0.94** for all ratios **input speed (n₁) = 1400 min⁻¹**

Output Speed n ₂ [min ⁻¹]	Ratio i	Motor power P _{1M} [kW]	Output torque M _{2M} [Nm]	Service factor f.s.	Nominal power P _{1R} [kW]	Nominal torque M _{2R} [Nm]	Available B5 motor flanges				Available B14 motor flanges			Output Shaft 	Ratios code
							-B	-C	-D	-E	-Q	-R	-T		
							63	71	80	90	71	80	90		
24.7	56.76	0.55	201	1.2	0.69	250	B				C	C		191311	01
21.3	65.79	0.55	233	1.1	0.59	250	B				C	C		171311	02
18.1	77.23	0.55	274	0.9	0.50	250	B				C	C		151311	03
16.0	87.23	0.37	207	1.2	0.45	250	B				C	C		19138	04
15.2	92.18	0.37	219	1.1	0.42	250	B				C	C		131311	05
13.9	100.47	0.37	238	1.0	0.39	250	B				C	C		19811	06
12.0	116.45	0.37	276	0.9	0.33	250	B				C	C		17811	07
11.1	125.82	0.25	201	1.2	0.31	250	B				C	C		101311	08
9.9	141.66	0.25	227	1.1	0.28	250	B				C	C		13138	09
8.6	163.16	0.25	261	1.0	0.24	250	B				C	C		13811	10
7.8	178.96	0.18	219	1.1	0.22	250	B				C	C		1788	11
7.2	193.36	0.18	237	1.1	0.20	250	B				C	C		10138	12
6.5	216.84	0.18	265	0.9	0.18	250	B				C	C		71311	13
5.5	252.36	0.12	200	1.3	0.15	250	B				C	C		9138	14
4.8	290.67	0.12	230	1.1	0.13	250	B				C	C		9811	15
4.2	333.23	0.12	263	0.9	0.12	250	B				C	C		7138	16
3.6	383.82	0.12	303	0.8	0.10	250	B				C	C		7811	17
3.1	446.70	0.12*	353	0.7	0.09	250	B				C	C		988	18
2.4	589.85	0.12*	466	0.5	0.07	250	B				C	C		788	19

Motor Flanges Available Flange Motore Disponibili
 B) Supplied with Reduction Bushing Fornito con Bussola di Riduzione
 B) Available on Request without reduction bushing Disponibile a Richiesta senza Bussola di Riduzione
 C) Motor Flange Holes Position Posizione Fori Flangia Motore

* Power higher than the maximum one which can be supported by the gearbox. Select according to the torque M_{2R}
Potenza superiore a quella massima sopportabile dal riduttore. Selezionare in base al momento torcente M_{2R}

EN Unit **X53A** is supplied with synthetic oil for lifetime lubrication, no maintenance is necessary. See table 1 for lubrication and recommended quantity. In table 2 please see possible radial loads and axial loads on the gearbox.

I Il riduttore **X53A** viene fornito completo di olio sintetico per la lubrificazione permanente e non necessita di alcuna manutenzione. Vedi tab.1 per oli e quantità consigliati. In tab.2 sono presenti i carichi radiali e assiali applicabili al riduttore.

D Das Getriebe **X53A** ist mit synthetischem Öl gefüllt und ist lebensdauergeschmiert. In Tabelle 1 ist die Schmiermenge und das empfohlene Schmiermittel angegeben. In Tabelle 2 sind die zulässigen Radial- und Axialbelastungen des Getriebes aufgeführt.

F Le réducteur **X53A** est fourni complet avec de l'huile synthétique pour la lubrification permanente et ne nécessite aucun entretien. Voir tableau 1 concernant les huiles et les quantités conseillées. Les charges radiales et axiales applicables au réducteur sont précisées dans le tableau 2.

E El reductor tamaño **X53A** se suministra, lubricado de por vida con aceite sintético y no requiren mantenimiento alguna. Ver tabla 1, para cantidades y aceites recomendados. En la tabla 2, se encuentran las cargas radiales y axiales admitidas por el reductor.

Standard supplied	For these mounting position specify in the order or add oil Per queste posizioni specificare in fase d'ordine o aggiungere olio					
B3	B6	B7	B8	V5	V6	V8
1.30 LT	1.55 LT	0.85 LT	1.45 LT	2.10 LT	1.25 LT	Ask
AGIP Telium VSF 320				SHELL Omala S4 WE 320		

For all details on lubrication and plugs check our website **tab. 1**
Per maggiori dettagli su lubrificazione e tappi olio vedi il nostro sito web

RADIAL AND AXIAL LOADS

Output shaft
Albero di uscita

$$F_{eq} = F_R \cdot \frac{61.5}{X+31}$$

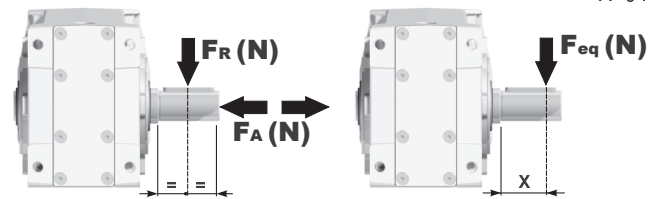

n ₂ [min ⁻¹]	FA	FR	n ₂ [min ⁻¹]	FA	FR	n ₂ [min ⁻¹]	FA	FR
250	600	3000	75	820	4100	15	1660	8300
150	700	3500	50	960	4800			
100	800	4000	25	1350	6750			

F_R On request taper roller bearings to increase radial loads.
A richiesta cuscinetti a rulli conici per aumentare i carichi radiali.

Input shaft
albero in entrata

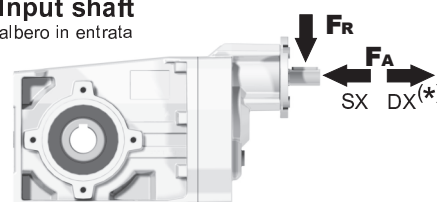

n ₁ [min ⁻¹]	FA [N]	FR [N]
1400	400	2000
900	440	2200
500	440	2200

*Strong axial loads in the DX direction are not allowed.
Non sono consentiti forti carichi assiali con direzione DX

tab. 2

PX53AC... Basic Gearbox
Riduttore base

Gearbox weight **12.65 kg**
peso riduttore

M. flanges	Kit code	øF	A
63B5	K063.4.041	140	246
71B5	K063.4.042	160	244
80/90B5	K063.4.043	200	246
71B14	K063.4.047	105	244
80B14	K063.4.046	120	246
90B14	K063.4.041	140	246

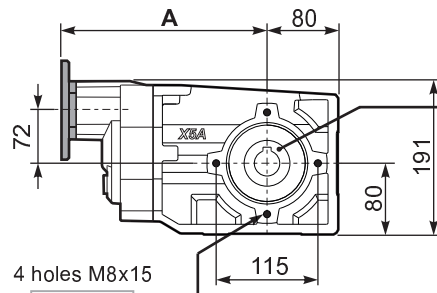
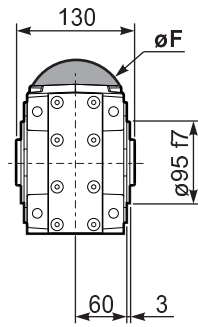

4 holes M8x15
Mounting holes position
Posizione fori di montaggio

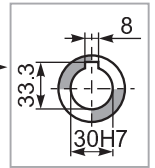

Standard
Hollow shaft

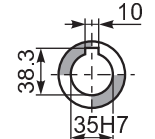

On request
A richiesta

PX53A...FB.. Feet
Piedini

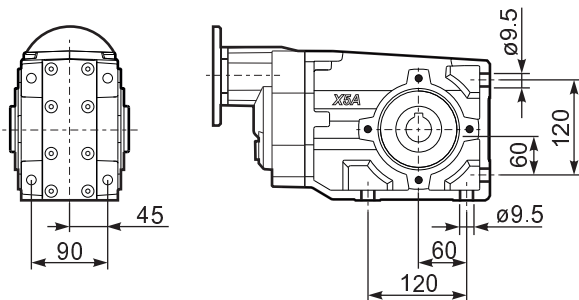

PX53A...-F2.. Output flange
Flangia uscita

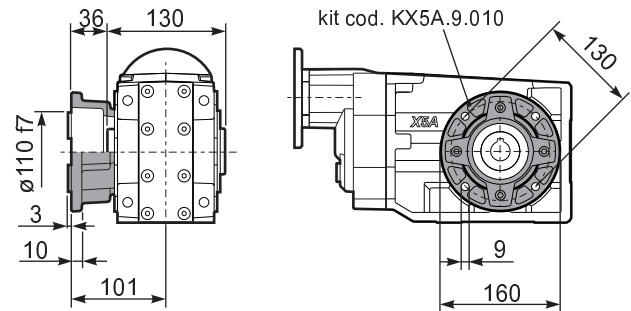

PX53A...-F3.. Output flange
Flangia uscita

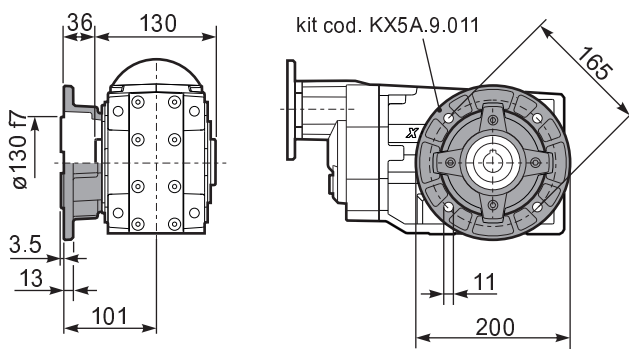

PX53A...-F4.. Output flange
Flangia uscita

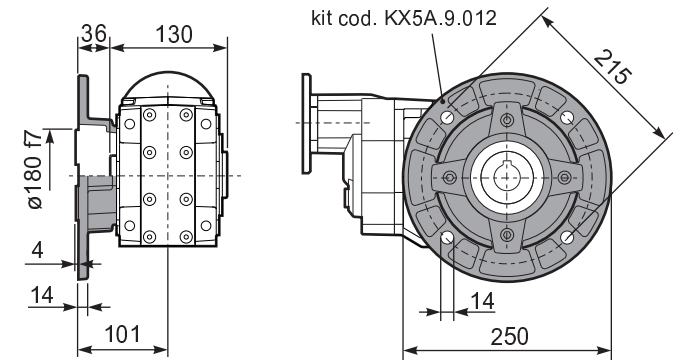

RX53A... Input shaft
Albero in entrata

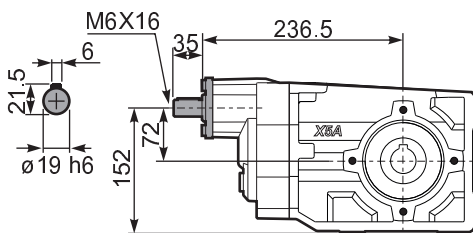

PX53A...BR.. Reaction Arm
Braccio di reazione

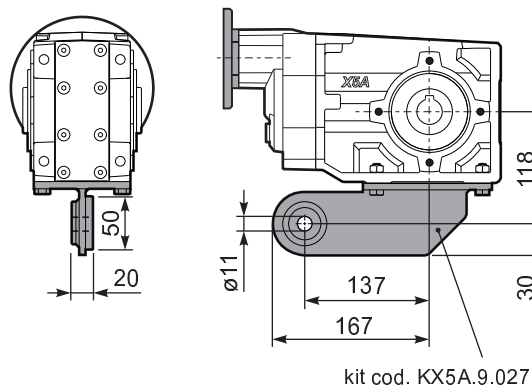

PX53A... Single output shaft
Albero semplice in uscita

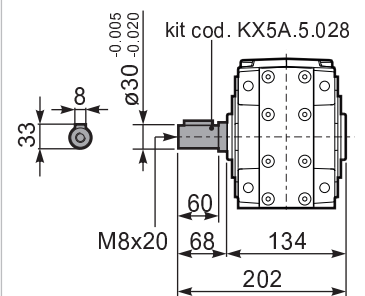

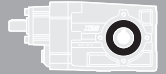

QUICK SELECTION / Selezione veloce The dynamic efficiency is **0.96** for all ratios **input speed (n₁) = 1400 min⁻¹**

Output Speed n ₂ [min ⁻¹]	Ratio i	Motor power P _{1M} [kW]	Output torque M _{2M} [Nm]	Service factor f.s.	Nominal power P _{1R} [kW]	Nominal torque M _{2R} [Nm]	Available B5 motor flanges					Available B14 motor flanges				Output Shaft 	Ratios code	
							-C	-D	-E	-F	-G	-R	-T	-U	-V			
							71	80	90	100 112	132	80	90	100 112	132			
232	6.03	5.5	211	1.1	6.1	240	B										3011	01
151	9.26	4	238	1.1	4.5	270	B										308	02
123	11.36	4	291	1.2	4.7	350	B										2011	03
91	15.36	4	394	1.0	3.8	385	B										1611	04
80	17.46	4	448	0.9	3.5	400	B										208	05
70	19.97	3	386	1.1	3.1	410	B										1311	06
59	23.60	3	456	0.9	2.7	410	B										168	07
57	24.45	3	472	0.9	2.6	410	B										1111	08
45.6	30.69	2.2	436	0.9	2.0	410	B										138	09
39.6	35.35	1.5	346	1.2	1.8	410	B										811	10
37.3	37.57	1.5	368	1.1	1.7	410	B										118	11
28.8	48.68	1.1	348	1.0	1.1	365	B										611	12
25.8	54.33	1.1	389	1.1	1.2	410	B										88	13
18.7	74.81	0.75	367	1.0	0.73	360	B										68	14

A) Motor Flanges Available
Flange Motore Disponibili

B) Supplied with Reduction Bushing
Fornito con Bussola di Riduzione

B) Available on Request without reduction bushing
Disponibile a Richiesta senza Bussola di Riduzione

C) Motor Flange Holes Position
Posizione Fori Flangia Motore

EN Unit **X62A** is supplied with synthetic oil for lifetime lubrication, no maintenance is necessary. See table 1 for lubrication and recommended quantity. In table 2 please see possible radial loads and axial loads on the gearbox.

I Il riduttore **X62A** viene fornito completo di olio sintetico per la lubrificazione permanente e non necessita di alcuna manutenzione. Vedi tab.1 per oli e quantità consigliati. In tab.2 sono presenti i carichi radiali e assiali applicabili al riduttore.

D Das Getriebe **X62A** ist mit synthetischem Öl gefüllt und ist lebensdauergeschmiert. In Tabelle 1 ist die Schmiermenge und das empfohlene Schmiermittel angegeben. In Tabelle 2 sind die zulässigen Radial - und Axialbelastungen des Getriebes aufgeführt.

F Le réducteur **X62A** est fourni complet avec de l'huile synthétique pour la lubrification permanente et ne nécessite aucun entretien. Voir tableau 1 concernant les huiles et les quantités conseillées. Les charges radiales et axiales applicables au réducteur sont précisées dans le tableau 2.

E El reductor tamaño **X62A** se suministra, lubricado de por vida con aceite sintético y no requieren mantenimiento alguna. Ver tabla 1, para cantidades y aceites recomendados. En la tabla 2, se encuentran las cargas radiales y axiales admitidas por el reductor.

Standard supplied	For these mounting position specify in the order or add oil Per queste posizioni specificare in fase d'ordine o aggiungere olio						
B3	B6	B7	B8	V5	V6	V8	V8
1.25 LT	1.70 LT	0.95 LT	1.60 LT	2.45 LT	1.50 LT	Ask	Ask
AGIP Telium VSF 320				SHELL Omala S4 WE 320			

For all details on lubrication and plugs check our website **tab. 1**
Per maggiori dettagli su lubrificazione e tappi olio vedi il nostro sito web

RADIAL AND AXIAL LOADS

Output shaft
Albero di uscita

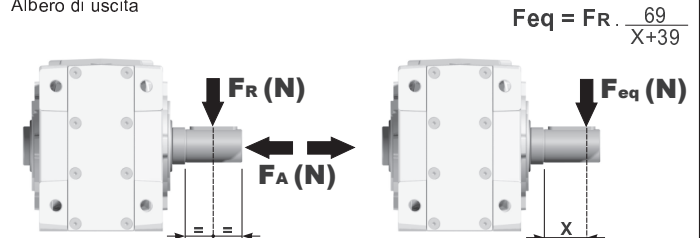

n ₂ [min ⁻¹]	FA	FR	n ₂ [min ⁻¹]	FA	FR	n ₂ [min ⁻¹]	FA	FR
250	600	3000	75	890	4450	15	1660	8300
150	700	3500	50	1140	5700			
100	780	3900	25	1330	6650			

FR On request taper roller bearings to increase radial loads.
A richiesta cuscinetti a rulli conici per aumentare i carichi radiali.

Input shaft
albero in entrata

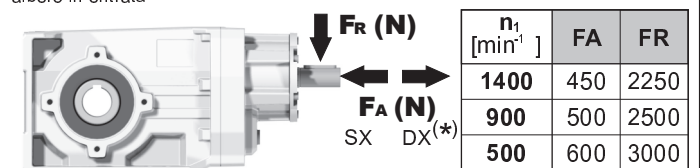

*Strong axial loads in the DX direction are not allowed.
Non sono consentiti forti carichi assiali con direzione DX

tab. 2

PX62AC... Basic Gearbox
Riduttore base

Gearbox weight **15.80 kg**
peso riduttore

M. flanges	Kit code	øF	A
71B5	K023.4.041	160	253
80/90B5	K023.4.042	200	255
100/112B5	K023.4.043	250	264
132B5	KC50.4.043	300	282
80B14	K085.4.046	120	255
90B14	K085.4.045	140	255
100/112B14	K085.4.047	160	264
132B14	KC50.4.041	200	282

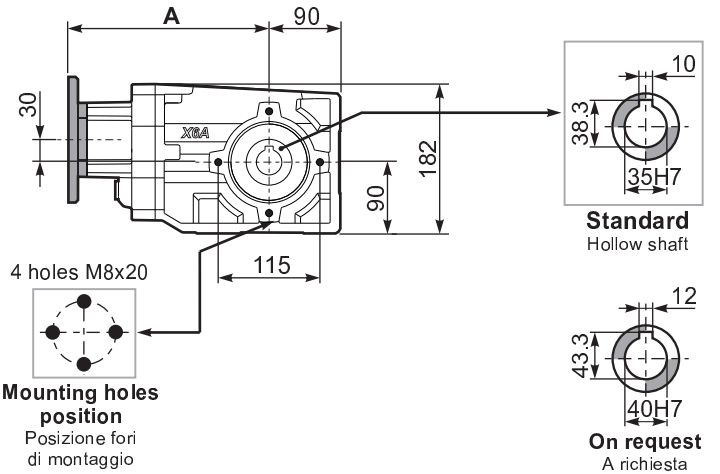
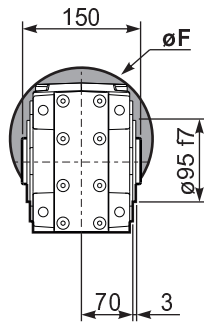

PX62A...FB.. Feet
Piedini

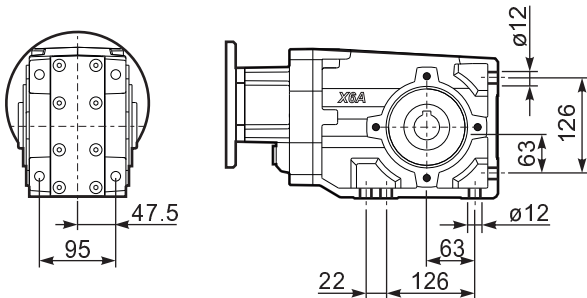

PX62A...-F2.. Output flange
Flangia uscita

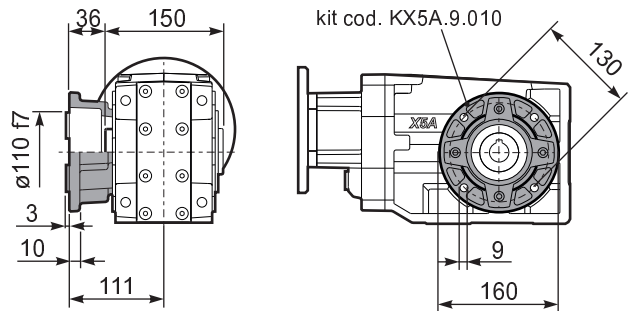

PX62A...-F3.. Output flange
Flangia uscita

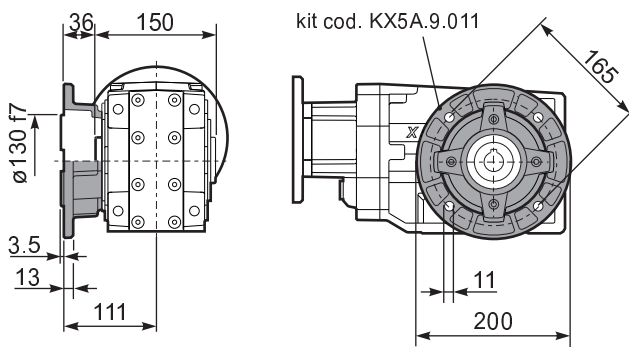

PX62A...-F4.. Output flange
Flangia uscita

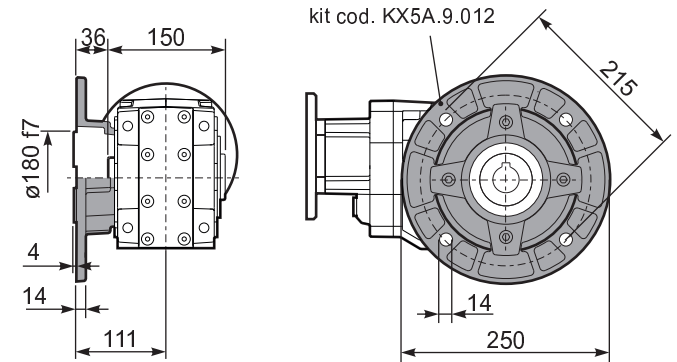

RX62A... Input shaft
Albero in entrata

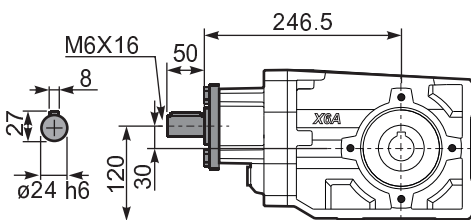

PX62A...BR.. Reaction Arm
Braccio di reazione

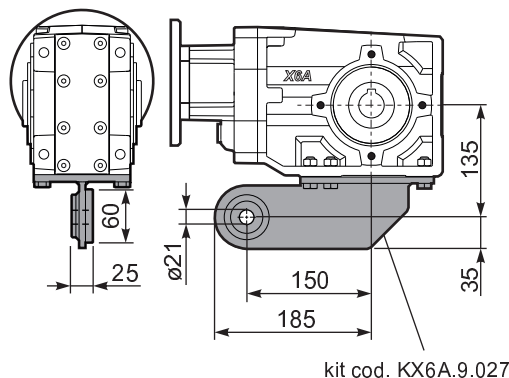

PX62AA.. Single output shaft
Albero semplice in uscita

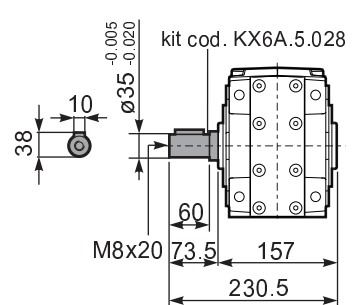

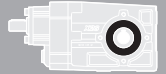

QUICK SELECTION / Selezione veloce The dynamic efficiency is **0.94** for all ratios **input speed (n₁) = 1400 min⁻¹**

Output Speed n ₂ [min ⁻¹]	Ratio i	Motor power P _{1M} [kW]	Output torque M _{2M} [Nm]	Service factor f.s.	Nominal power P _{1R} [kW]	Nominal torque M _{2R} [Nm]	Available B5 motor flanges				Available B14 motor flanges			Output Shaft 	Ratios code
							-B	-C	-D	-E	-Q	-R	-T		
							63	71	80	90	71	80	90		
24.7	56.76	1.1	398	1.0	1.1	410	B				C	C		191311	01
21.3	65.79	0.75	316	1.3	0.97	410	B				C	C		171311	02
18.1	77.23	0.75	371	1.1	0.83	410	B				C	C		151311	03
16.0	87.23	0.75	420	1.0	0.73	410	B				C	C		19138	04
15.2	92.18	0.75	443	0.9	0.69	410	B				C	C		131311	05
13.9	100.47	0.55	357	1.2	0.64	410	B				C	C		19811	06
12.0	116.45	0.55	413	1.0	0.55	410	B				C	C		17811	07
11.1	125.82	0.55	446	0.9	0.51	410	B				C	C		101311	08
9.9	141.66	0.37	336	1.2	0.45	410	B				C	C		13138	09
8.6	163.16	0.37	387	1.1	0.39	410	B				C	C		13811	10
7.8	178.96	0.37	424	1.0	0.36	410	B				C	C		1788	11
7.2	193.36	0.37	459	0.9	0.33	410	B				C	C		10138	12
6.5	216.84	0.25	347	1.2	0.29	410	B				C	C		71311	13
5.5	252.36	0.25	404	1.0	0.25	410	B				C	C		9138	14
4.8	290.67	0.25	465	0.9	0.22	410	B				C	C		9811	15
4.2	333.23	0.18	408	1.0	0.19	410	B				C	C		7138	16
3.6	383.82	0.18	470	0.9	0.17	410	B				C	C		7811	17
3.1	446.70	0.12	353	1.2	0.14	410	B				C	C		988	18
2.4	589.85	0.12	466	0.9	0.11	410	B				C	C		788	19

Motor Flanges Available Flange Motore Disponibili
 B) Supplied with Reduction Bushing Fornito con Bussola di Riduzione
 B) Available on Request without reduction bushing Disponibile a Richiesta senza Bussola di Riduzione
 C) Motor Flange Holes Position Posizione Fori Flangia Motore

EN Unit **X63A** is supplied with synthetic oil for lifetime lubrication, no maintenance is necessary. See table 1 for lubrication and recommended quantity. In table 2 please see possible radial loads and axial loads on the gearbox.

I Il riduttore **X63A** viene fornito completo di olio sintetico per la lubrificazione permanente e non necessita di alcuna manutenzione. Vedi tab.1 per oli e quantità consigliati. In tab.2 sono presenti i carichi radiali e assiali applicabili al riduttore.

D Das Getriebe **X63A** ist mit synthetischem Öl gefüllt und ist lebensdauergeschmiert. In Tabelle 1 ist die Schmiermenge und das empfohlene Schmiermittel angegeben. In Tabelle 2 sind die zulässigen Radial - und Axialbelastungen des Getriebes aufgeführt.

F Le réducteur **X63A** est fourni complet avec de l'huile synthétique pour la lubrification permanente et ne nécessite aucun entretien. Voir tableau 1 concernant les huiles et les quantités conseillées. Les charges radiales et axiales applicables au réducteur sont précisées dans le tableau 2.

E El reductor tamaño **X63A** se suministra, lubricado de por vida con aceite sintético y no requieren mantenimiento alguna. Ver tabla 1, para cantidades y aceites recomendados. En la tabla 2, se encuentran las cargas radiales y axiales admitidas por el reductor.

Standard supplied	For these mounting position specify in the order or add oil Per queste posizioni specificare in fase d'ordine o aggiungere olio						
1.80 LT	1.80 LT	1.05 LT	1.70 LT	2.60 LT	1.65 LT	Ask	
AGIP Telium VSF 320				SHELL Omala S4 WE 320			

For all details on lubrication and plugs check our website **tab. 1**
Per maggiori dettagli su lubrificazione e tappi olio vedi il nostro sito web

RADIAL AND AXIAL LOADS

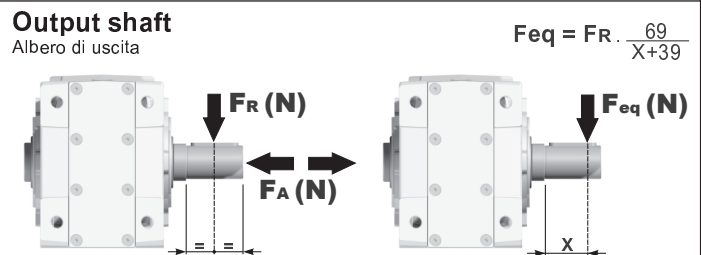

n ₂ [min ⁻¹]	FA	FR	n ₂ [min ⁻¹]	FA	FR	n ₂ [min ⁻¹]	FA	FR
250	600	3000	75	890	4450	15	1660	8300
150	700	3500	50	1140	5700			
100	780	3900	25	1330	6650			

FR On request taper roller bearings to increase radial loads.
A richiesta cuscinetti a rulli conici per aumentare i carichi radiali.

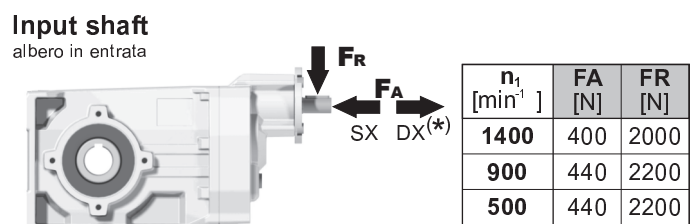

*Strong axial loads in the DX direction are not allowed.
Non sono consentiti forti carichi assiali con direzione DX

tab. 2

PX63AC... Basic Gearbox
Riduttore base

Gearbox weight **15.98 kg**
peso riduttore

M. flanges	Kit code	øF	A
63B5	K063.4.041	140	265
71B5	K063.4.042	160	263
80/90B5	K063.4.043	200	265
71B14	K063.4.047	105	263
80B14	K063.4.046	120	265
90B14	K063.4.041	140	265

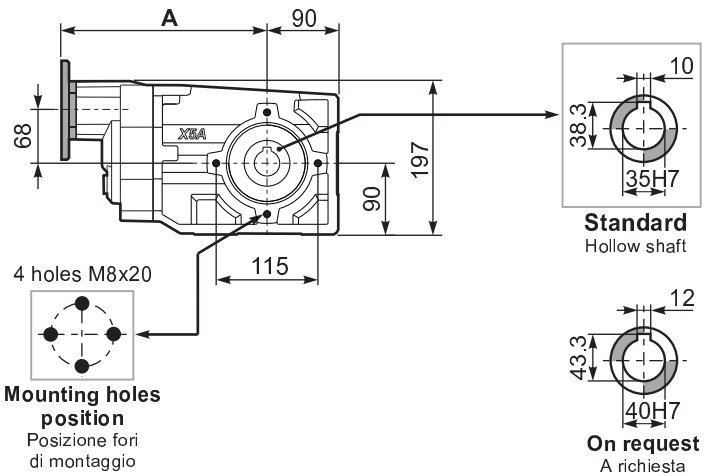
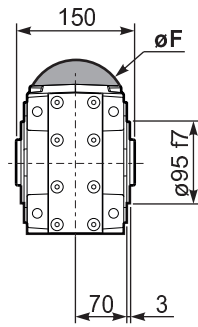

PX63A...FB.. Feet
Piedini

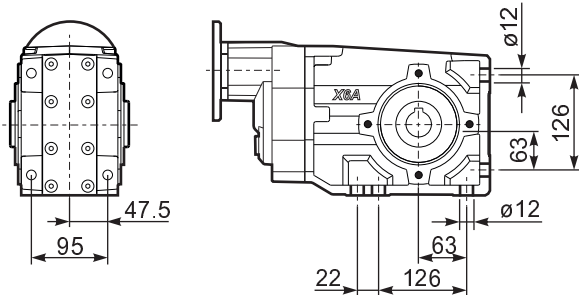

PX63A...-F2.. Output flange
Flangia uscita

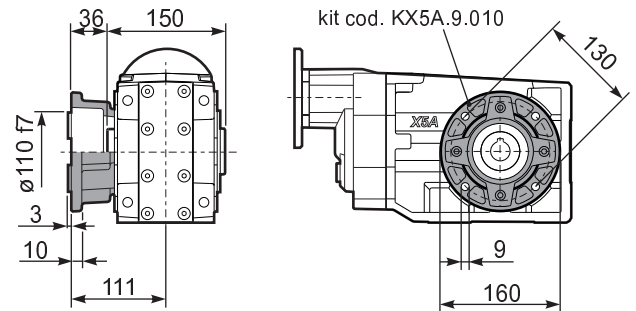

PX63A...-F3.. Output flange
Flangia uscita

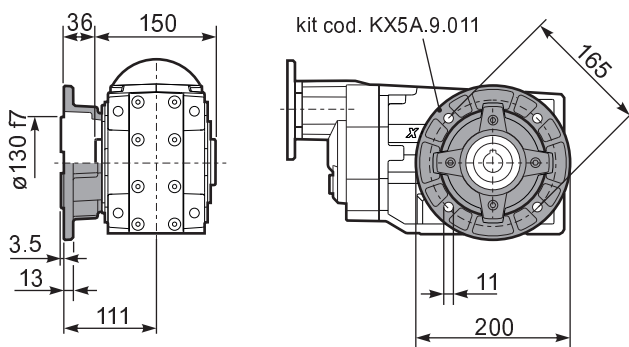

PX63A...-F4.. Output flange
Flangia uscita

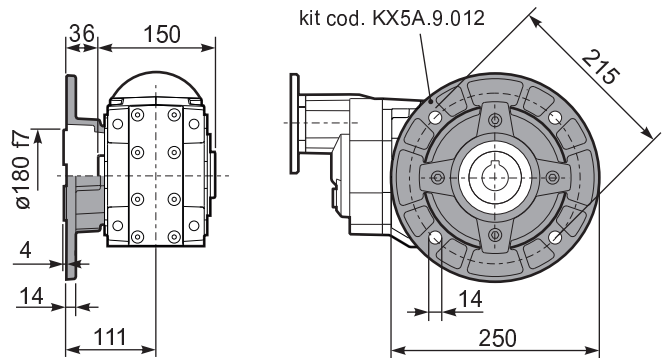

RX63A... Input shaft
Albero in entrata

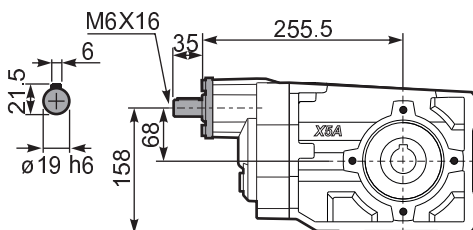

PX63A...BR.. Reaction Arm
Braccio di reazione

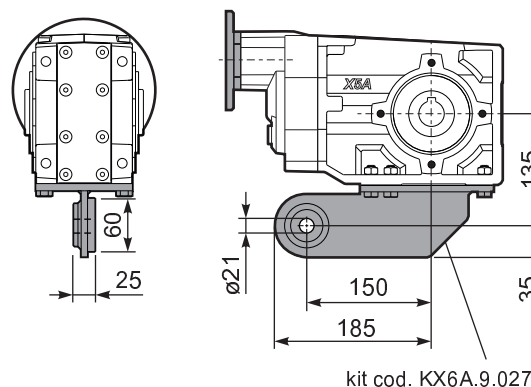

PX63AA.. Single output shaft
Albero semplice in uscita

