

S1 service, F insulation class			Operating characteristics at rated power							Direct starting					Enclosure	
Power	Motor code	Frame	Rated current	Speed	Nominal torque	Efficiency at % load			PF	Torque	Current	Inertia moment	Weight B14	R [Ω] 20°C		
kW			A 400/460V	rpm	Nm	100%	75%	50%	cos φ	Ms/Mn	Is/In	[kgm ²]	Kg			
230/400V 50Hz rpm 3000	0.18	SPM BKD2J TEN	63A	0.45	2890	0.60	70.8	67.5	64.2	0.81	4.1	6.4	0.0005	8.2	29.1	TEN
	0.25	SPM BKE2J TEN	63B	0.58	2895	0.84	74.3	72.8	70.5	0.85	4.4	7.8	0.0006	9.8	13.8	
	0.37	SPM CKF2J TEN	71A	0.85	2930	1.23	82.5	80.1	77.2	0.75	4.3	8.8	0.0008	11.8	7.9	
	0.55	SPM CKG2J TEN	71B	1.24	2910	1.85	82.9	81.4	77.5	0.77	5.4	8.9	0.0010	13.2	6.2	
	0.75	SPM DKH2J TEN	80A	1.52	2900	2.45	84.6	83.9	80.8	0.83	6.2	12.5	0.0013	16.6	4.5	
	1.1	SPM DKI2J TEN	80B	2.10	2910	3.60	86.4	86.0	84.0	0.86	5.8	12.8	0.0017	21.8	3.3	
	1.5	SPM EKK2J TEN	90S	3.00	2930	4.90	86.5	85.5	82.3	0.83	5.2	10.5	0.0054	32.6	1.8	
	2.2	SPM EKL2J TEN	90L	4.20	2920	7.20	86.0	85.0	82.0	0.82	4.8	8.5	0.0056	33.5	1.7	
	3.0	SPM FKM2J TEV	100LA	5.50	2910	9.80	87.1	86.5	83.0	0.85	4.7	9.5	0.0062	38.5	1.4	TEFC
230/460V 60Hz rpm 3600	0.18	SPM BKD2J TUN	63A	0.41	3461	0.50	70.9	68.1	64.9	0.78	4.3	6.6	0.0005	8.2	29.1	TEN
	0.25	SPM BKE2J TUN	63B	0.53	3503	0.70	71.3	68.2	64.9	0.77	4.6	8.0	0.0006	9.7	13.8	
	0.37	SPM CKF2J TUN	71A	0.77	3545	1.00	82.5	80.1	77.2	0.72	4.5	9.0	0.0008	11.8	7.8	
	0.55	SPM CKG2J TUN	71B	1.12	3521	1.50	83.0	81.3	77.4	0.74	5.6	9.1	0.0010	13.2	6.2	
	0.75	SPM DKH2J TUN	80A	1.38	3509	2.00	84.8	83.6	80.6	0.83	6.4	12.7	0.0013	16.6	4.5	
	1.1	SPM DKI2J TUN	80B	1.97	3521	3.00	86.6	86.0	84.2	0.80	6.0	13.0	0.0017	21.8	3.2	
	1.5	SPM EKK2J TUN	90S	2.78	3545	4.10	86.6	85.4	82.2	0.74	5.4	10.7	0.0054	32.6	1.7	
	2.2	SPM EKL2J TUN	90L	3.82	3520	6.00	88.7	87.8	86.0	0.82	4.8	9.2	0.0056	34.0	1.5	
	3.0	SPM FKM2J TUV	100LA	4.80	3510	8.10	88.5	87.6	86.4	0.86	5.2	9.6	0.0062	35.5	1.2	TEFC

Nominal values with ±10% tolerance on Voltage Valori nominali con ±10% di tolleranza nel voltaggio

Technical data and performances may change Dati tecnici e prestazioni possono subire variazioni



TENV Totally Enclosed non ventilated
Totalmente chiuso, non ventilato

S3 For S3 intermittent periodic duty, see page 3-6 Per il servizio intermittente periodico S3, vedere pagina 3-6

	S1 service, F insulation class			Operating characteristics at rated power						Direct starting					Enclosure	
	Power	Motor code	Frame	Rated current	Speed	Nominal torque	Efficiency at % load			PF	Torque	Current	Inertia moment	Weight B14		R [Ω] 20°C
	kW			A 400/460V	rpm	Nm	100%	75%	50%	cos φ	Ms/Mn	Is/In	[kgm ²]	Kg		
230/400V 50Hz rpm 1500	0.12	SPM BKC4J TEN	63A	0.40	1445	0.81	71.6	70.0	63.9	0.64	3.5	6.5	0.0014	8.8	41.8	TEN
	0.18	SPM BKD4J TEN	63B	0.48	1445	1.21	75.7	74.1	69.3	0.72	3.8	6.6	0.0016	9.7	30.1	
	0.25	SPM CKE4J TEN	71A	0.64	1444	1.66	76.7	74.8	70.1	0.73	3.7	7.2	0.0021	11.5	21.1	
	0.37	SPM CKF4J TEN	71B	0.94	1440	2.45	80.7	79.7	75.9	0.71	4.1	7.4	0.0025	13.2	12.8	
	0.55	SPM DKG4J TEN	80A	1.34	1448	3.66	81.6	80.7	77.0	0.73	4.8	8.2	0.0026	16.2	8.1	
	0.75	SPM DKH4J TEN	80B	1.74	1456	4.95	83.6	82.5	79.2	0.74	5.6	8.5	0.0032	18.7	5.7	
	1.1	SPM EKI4J TEN	90S	2.50	1475	7.15	87.2	84.4	80.3	0.73	4.8	8.6	0.0095	32.4	2.0	
	1.5	SPM EKK4J TEN	90L	3.34	1475	9.75	87.9	87.1	84.3	0.74	4.9	9.8	0.0107	35.4	1.5	
	2.2	SPM FKL4J TEV	100	4.80	1445	14.5	88.1	87.5	84.2	0.76	4.8	9.6	0.0108	37.5	1.5	TEFC
230/460V 60Hz rpm 1800	0.12	SPM BKC4J TUN	63A	0.34	1752	0.65	72.6	71.0	64.9	0.65	3.7	6.7	0.0014	8.8	41.8	TEN
	0.18	SPM BKD4J TUN	63B	0.41	1750	0.98	76.6	75.1	70.3	0.72	4.0	6.8	0.0016	9.7	30.1	
	0.25	SPM CKE4J TUN	71A	0.57	1748	1.36	77.7	75.8	71.1	0.70	3.9	7.4	0.0021	11.5	21.1	
	0.37	SPM CKF4J TUN	71B	0.84	1742	2.02	81.6	80.6	76.8	0.67	4.3	7.6	0.0025	13.2	12.8	
	0.55	SPM DKG4J TUN	80A	1.19	1750	3.05	82.6	81.7	78.0	0.70	5.0	8.4	0.0026	16.2	8.1	
	0.75	SPM DKH4J TUN	80B	1.52	1765	4.13	84.1	82.5	79.5	0.71	5.8	8.7	0.0032	18.7	5.7	
	1.1	SPM EKI4J TUN	90S	2.24	1780	5.96	88.0	84.1	80.1	0.70	5.0	8.8	0.0095	32.4	2.0	
	1.5	SPM EKK4J TUN	90L	2.96	1785	8.13	88.2	87.4	84.4	0.70	5.1	10.0	0.0107	35.4	1.5	
	2.2	SPM FKL4J TUV	100	4.20	1750	12.0	88.7	87.8	86.0	0.73	4.8	9.2	0.0108	37.5	1.5	TEFC

Nominal values with ±10% tolerance on Voltage Valori nominali con ±10% di tolleranza nel voltaggio

Technical data and performances may change Dati tecnici e prestazioni possono subire variazioni



TEFC

Totally Enclosed Fan Cooled
Totalmente chiuso, raffreddato a ventola

Frame B14, S1 service, F insulation class			Operating characteristics at rated power							Direct starting					Enclosure	
Power	Motor code	Frame	Rated current	Speed	Nominal torque	Efficiency at % load			PF	Torque	Current	Inertia moment	Weight B14	R [Ω] 20°C		
kW			A 400/460V	rpm	Nm	100%	75%	50%	cos φ	Ms/Mn	Is/In	[kgm ²]	Kg			
230/400V 50Hz rpm 1000	0.18	SPM CKD6J TEN	71A	0.55	890	1.95	70.2	67.2	60.1	0.68	2.6	3	0.0021	11.6	36.9	TENV
	0.25	SPM CKE6J TEN	71B	0.75	890	2.65	72.2	71.3	66.8	0.65	3.2	3.4	0.0025	13.4	26.1	
	0.37	SPM DKF6J TEN	80A	1.10	890	3.98	76.3	76.0	73.2	0.63	1.7	3.4	0.0026	16.5	18.8	
	0.55	SPM DKG6J TEN	80B	1.30	900	5.30	78.0	77.7	67.4	0.69	2.4	3.7	0.0032	18.9	13.1	
	0.75	SPM EKH6J TEN	90S	1.70	940	7.60	82.5	81.5	78.0	0.77	2.6	5.7	0.0095	32.5	4.9	
	1.1	SPM EKI6J TEN	90L	2.40	950	11.10	84.5	83.0	82.0	0.78	2.9	6.1	0.0107	35.6	4.2	
230/460V 60Hz rpm 1200	0.18	SPM CKD6J TUN	71A	0.50	1115	1.50	70.1	67.0	60.0	0.61	2.6	3	0.0021	11.6	42.6	TENV
	0.25	SPM CKE6J TUN	71B	0.68	1120	2.1	74.0	67.0	61.0	0.61	3.2	3.4	0.0025	13.4	24.3	
	0.37	SPM DKF6J TUN	80A	1.03	1125	3.10	76.3	74.4	73.2	0.57	1.7	3.4	0.0026	16.5	18.8	
	0.55	SPM DKG6J TUN	80B	1.35	1120	4.70	78.2	77.6	68.4	0.69	2.4	3.7	0.0032	18.9	13.1	
	0.75	SPM EKH6J TUN	90S	1.70	1128	6.2	82.3	81.0	78.0	0.69	2.6	5.7	0.0095	32.5	4.9	
	1.1	SPM EKI6J TUN	90L	2.20	1140	9.2	84.2	83.0	82.0	0.75	2.9	6.1	0.0107	35.6	4.2	

Nominal values with ±10% tolerance on Voltage Valori nominali con ±10% di tolleranza nel voltaggio

Technical data and performances may change Dati tecnici e prestazioni possono subire variazioni



TENV Totally Enclosed non ventilated
Totalmente chiuso, non ventilato

S3 For S3 intermittent periodic duty, see page 3-6 Per il servizio intermittente periodico S3, vedere pagina 3-6

Mounting arrangements and positions (IEC 60034-7)

Forme costruttive e posizioni di funzionamento (IEC 60034-7)

B14

Motors with fixing flange provided with threaded holes.

Motori con flangia di fissaggio a fori filettati

IMB14

Horizontal shaft.
Albero orizzontale.



IMB34

Horizontal shaft with foot.
Albero orizzontale con piede



B3

IMV18

Vertical downward shaft.
Albero verticale in basso.



IMV15

Vertical downward shaft with foot.
Albero verticale in basso con piede



IMV19

Vertical upward shaft.
Albero verticale in alto.



IMV36

Vertical upward shaft with foot.
Albero verticale in alto con piede.



B5

Motors with fixing flange provided with passing holes.

Motori con flangia di fissaggio a fori passanti.

IMB5

Horizontal shaft.
Albero orizzontale.



IMV1

Vertical downward shaft.
Albero verticale in basso.



IMV3

Vertical upward shaft.
Albero verticale in alto.



According to IEC 60034-7, there are two ways to define the configuration and installation position for an electric motor. In this table is indicated by the letters **IM** (International Mounting) followed by another letter (**B** = horizontal shaft; **V** = vertical shaft) and from a number.

*Le normative IEC 60034-7 prevede due modi alternativi di definire posizione di montaggio di un motore elettrico. Quello indicato in tabella definisce le lettere **IM** (International Mounting) seguite da un'altra lettera (**B** = albero orizzontale; **V** = albero verticale) e da un numero.*

TENV Totally Enclosed non ventilated Totamente chiuso non ventilato kW 0.12÷2.2

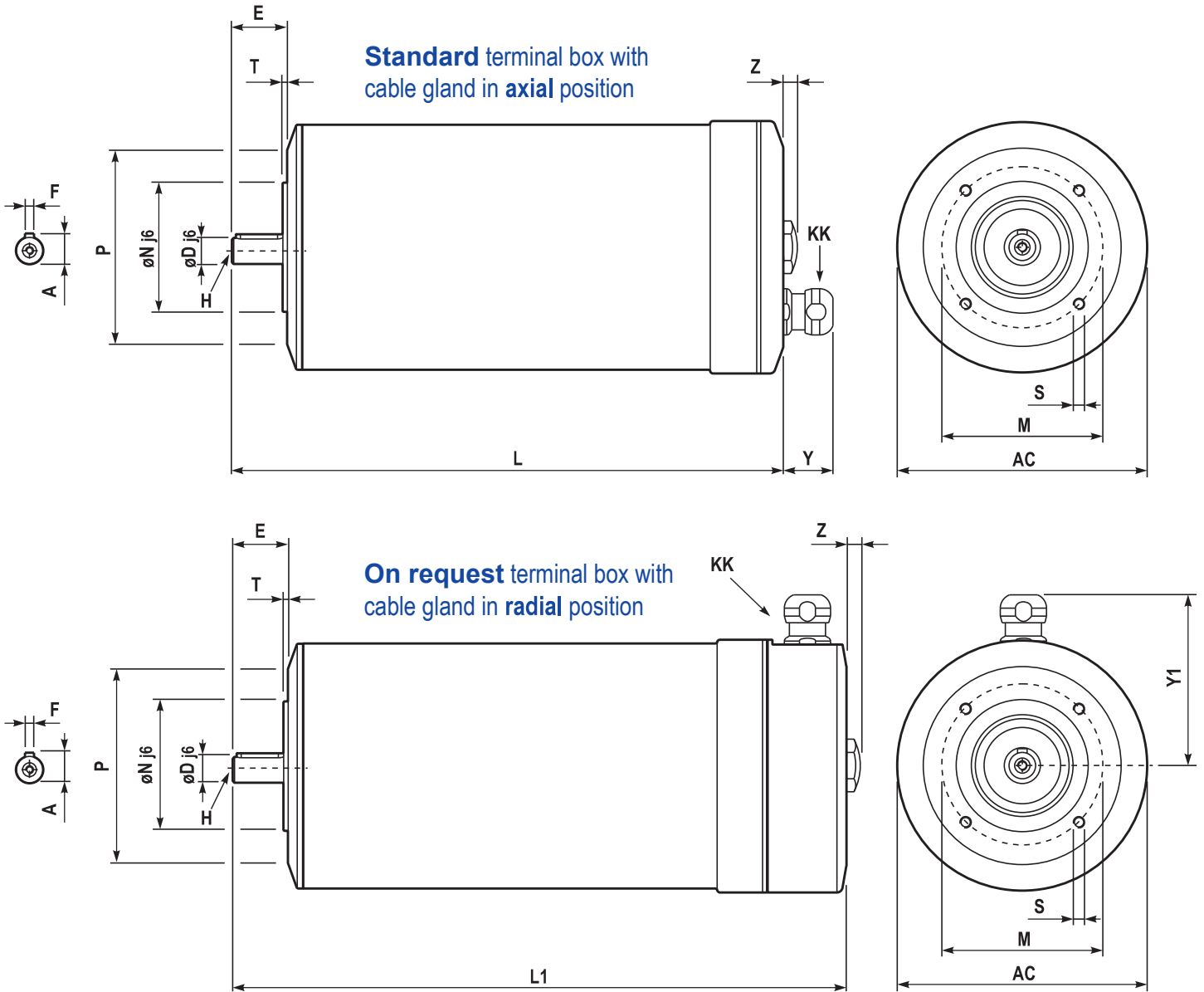

Dimensions

Dimensioni

Motor	2 poles kW	4 poles kW	6 poles kW	A	∅D j6 H	E	F	L	L1	M	∅N j6	P	S	T	AC	KK	Y	Y1	Z
63A	0.18	0.12	-	12.5	∅11	23	4	247.5	277	75	60	90	M5x13	2.5	133	M20x1.5	27.5	91.5	7.4
63B	0.25	0.18	-	12.5	M4x11	23	4	247.5	277	75	60	90	M5x13	2.5	133	M20x1.5	27.5	91.5	7.4
71A	0.37	0.25	0.18	16	∅14	30	5	294.5	324	85	70	105	M6x13	2.5	133	M20x1.5	27.5	91.5	7.4
71B	0.55	0.37	0.25	16	M5x12	30	5	294.5	324	85	70	105	M6x13	2.5	133	M20x1.5	27.5	91.5	7.4
80A	0.75	0.55	0.37	21.5	∅19	40	6	340	368.5	100	80	120	M6x13	3	143	M20x1.5	27.5	96.5	7.4
80B	1.1	0.75	0.55	21.5	M6x16	40	6	340	368.5	100	80	120	M6x13	3	143	M20x1.5	27.5	96.5	7.4
90S	1.5	1.1	0.75	27	∅24	50	8	372	401.5	115	95	140	M8x16	3	181	M20x1.5	27.5	116	7.4
90L	2.2	1.5	1.1	27	M8x20	50	8	372	401.5	115	95	140	M8x16	3	181	M20x1.5	27.5	116	7.4

SPM series Stainless steel premium motors

Motori elettrici in acciaio inox

B14

Dimensions

TEFC Totally Enclosed fan cooled
Totamente chiuso, raffreddato a ventola **kW 2.2÷3.0**

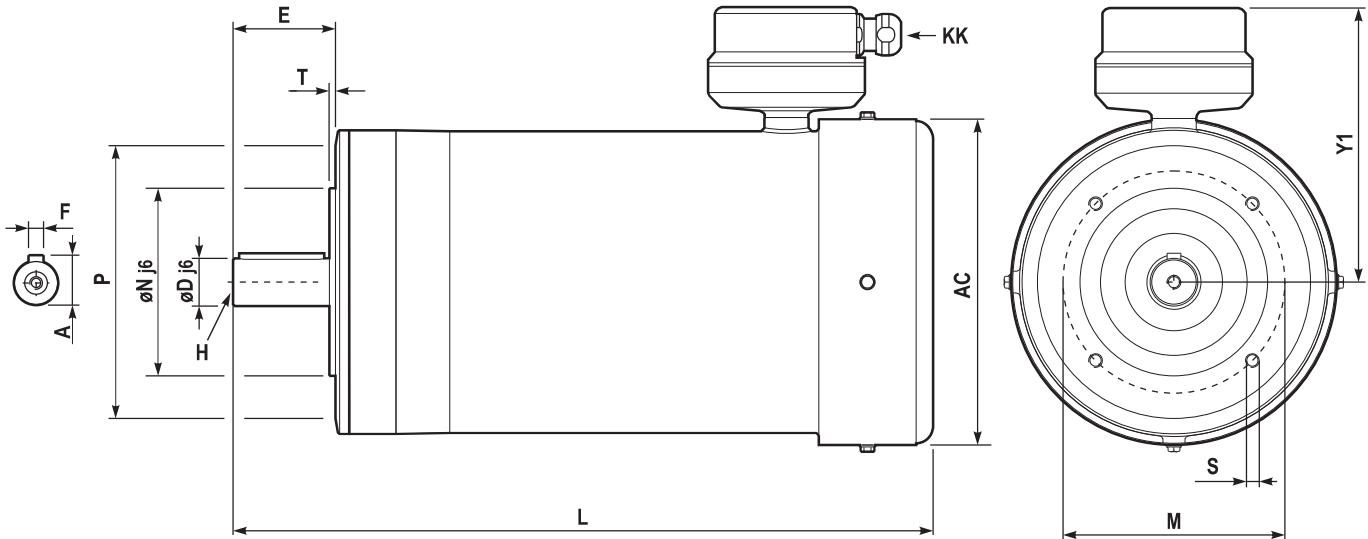

Motor fan and fan cover in stainless steel

All components of the motor fan and fan cover are made of stainless steel.
Tutti i componenti della ventola motore e copri ventola sono in acciaio inox.

Options With direct cable

On request with direct cable UL certified cable, resistant to hot temperature (+90°C).
A richiesta con cavo diretto certificato UL, resistente ad alte temperature (+90°C).



Standard with terminal box



On request with direct cable

Dimensions

Dimensioni

Motor	2 poles kW	4 poles kW	A	øD j6 H	E	F	L	M	øN j6	P	S	T	AC	KK	Y1
100LA	3.0	2.2	31	ø28 M8x20	60	8	410.5	130	110	160	M8x16	3.5	191	M20x1.5	163

TENV Totally Enclosed non ventilated Totamente chiuso non ventilato kW 0.18÷2.2

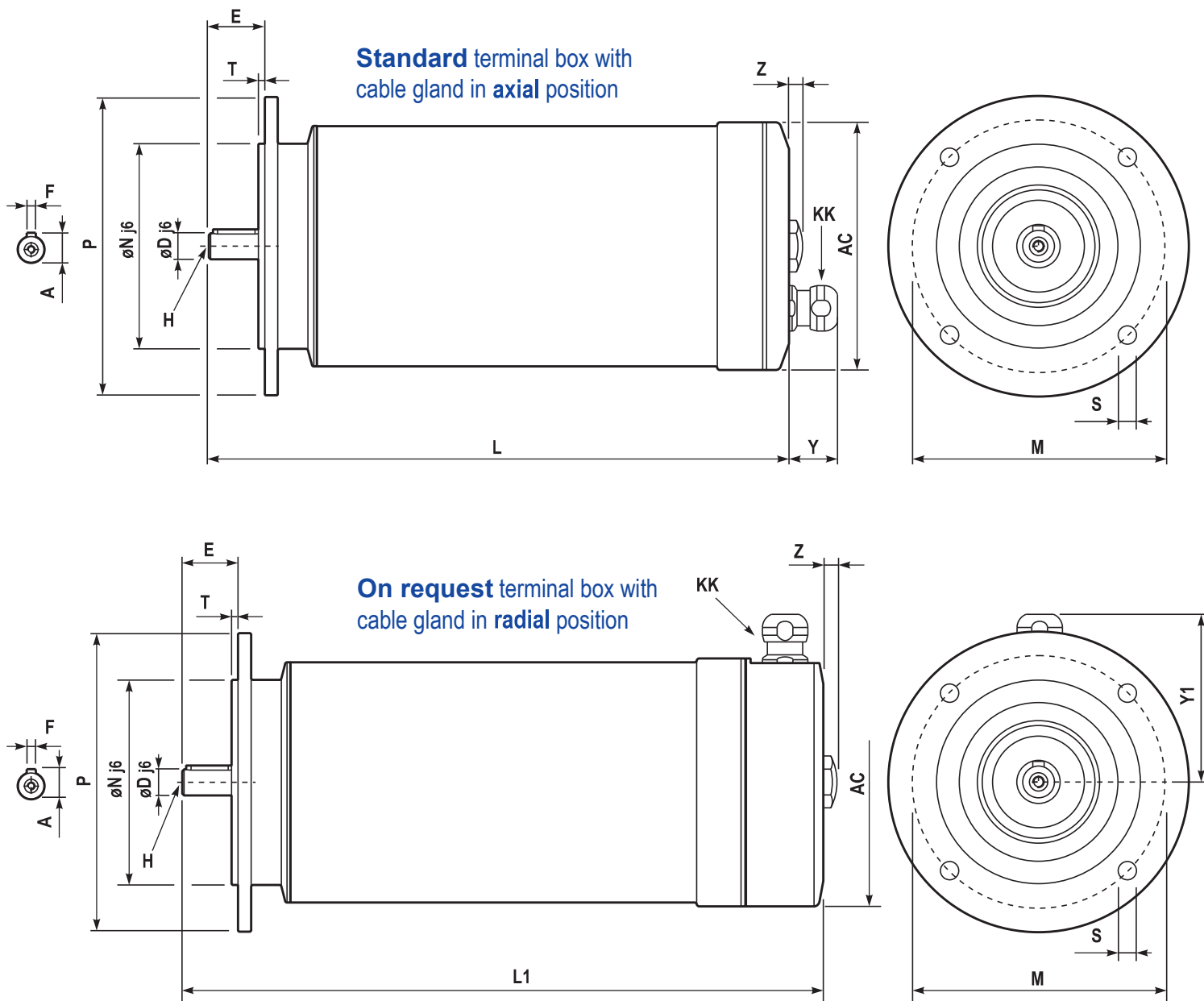

Dimensions

Dimensioni

Motor	2 poles kW	4 poles kW	6 poles kW	A	øD j6 H	E	F	L	L1	M	øN j6	P	S	T	AC	KK	Y	Y1	Z
71A	0.37	0.25	0.18	16	ø14	30	5	314.5	344	130	110	160	ø10	3.5	133	M20x1.5	27.5	91.5	7.4
71B	0.55	0.37	0.25		M5x12														
80A	0.75	0.55	0.37	21.5	ø19	40	6	340	368.5	165	130	200	ø12	3.5	143	M20x1.5	27.5	96.5	7.4
80B	1.1	0.75	0.55		M6x16														
90S	1.5	1.1	0.75	27	ø24	50	8	402	431.5	165	130	200	ø12	3.5	181	M20x1.5	27.5	116	7.4
90L	2.2	1.5	1.1		M8x20														

SPM series Stainless steel premium motors

Motori elettrici in acciaio inox

B3

Dimensions

TENV Totally Enclosed non ventilated with foot
Totalmente chiuso e non ventilato con piede **kW 0.12÷2.2**

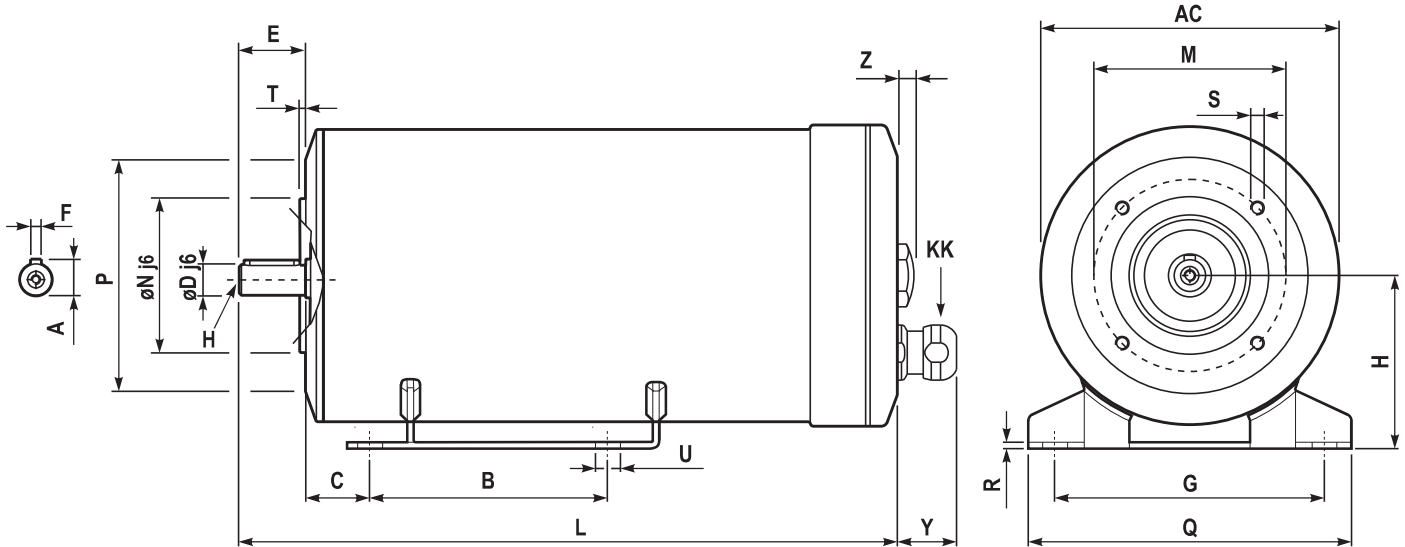

Feet fixing dimensions

Most of the dimensions of the feet are interchangeable with the brands in the market, except for the size 63 and 90.

La maggior parte delle dimensioni del piedino sono intercambiabili con i brand nel mercato, fatta eccezione per la grandezza 63 e 90.

Example of foot dimensions for size 90.

Esempio dimensioni piedino per grandezza 90.

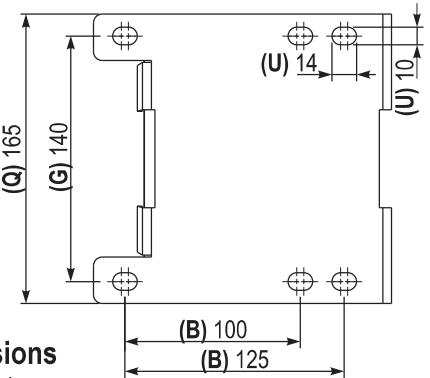

Foot dimensions

Dimensione piede

Motor	B	C	G	H	U	Q	R
63A	90	45	112	71	7x10	132	3
63B	90	45	112	71	7x10	132	3
71A	90	45	112	71	7x10	132	3
71B	90	45	112	71	7x10	132	3
80A	100	50	125	80	10x14	150	3
80B	100	50	125	80	10x14	150	3
90S	100	56	140	100	10x14	165	4
90L	125	56	140	100	10x14	165	4



Dimensions

Dimensioni

Motor	2 poles kW	4 poles kW	6 poles kW	A	øD j6 H	E	F	L	M	øN j6	P	S	T	AC	KK	Y	Z
63A	0.18	0.12	-	12.5	ø11	23	4	247.5	75	60	90	M5x13	2.5	133	M20x1.5	27.5	7.4
63B	0.25	0.18	-	12.5	M4x11	23	4	247.5	75	60	90	M5x13	2.5	133	M20x1.5	27.5	7.4
71A	0.37	0.25	0.18	16	ø14	30	5	294.5	85	70	105	M6x13	2.5	133	M20x1.5	27.5	7.4
71B	0.55	0.37	0.25	16	M5x12	30	5	294.5	85	70	105	M6x13	2.5	133	M20x1.5	27.5	7.4
80A	0.75	0.55	0.37	21.5	ø19	40	6	340	100	80	120	M6x13	3	143	M20x1.5	27.5	7.4
80B	1.1	0.75	0.55	21.5	M6x16	40	6	340	100	80	120	M6x13	3	143	M20x1.5	27.5	7.4
90S	1.5	1.1	0.75	27	ø24	50	8	372	115	95	140	M8x16	3	181	M20x1.5	27.5	7.4
90L	2.2	1.5	1.1	27	M8x20	50	8	372	115	95	140	M8x16	3	181	M20x1.5	27.5	7.4

TEFC Totally Enclosed fan cooled with foot **kW 2.2÷3.0**

Totalmente chiuso, raffreddato a ventola con piede

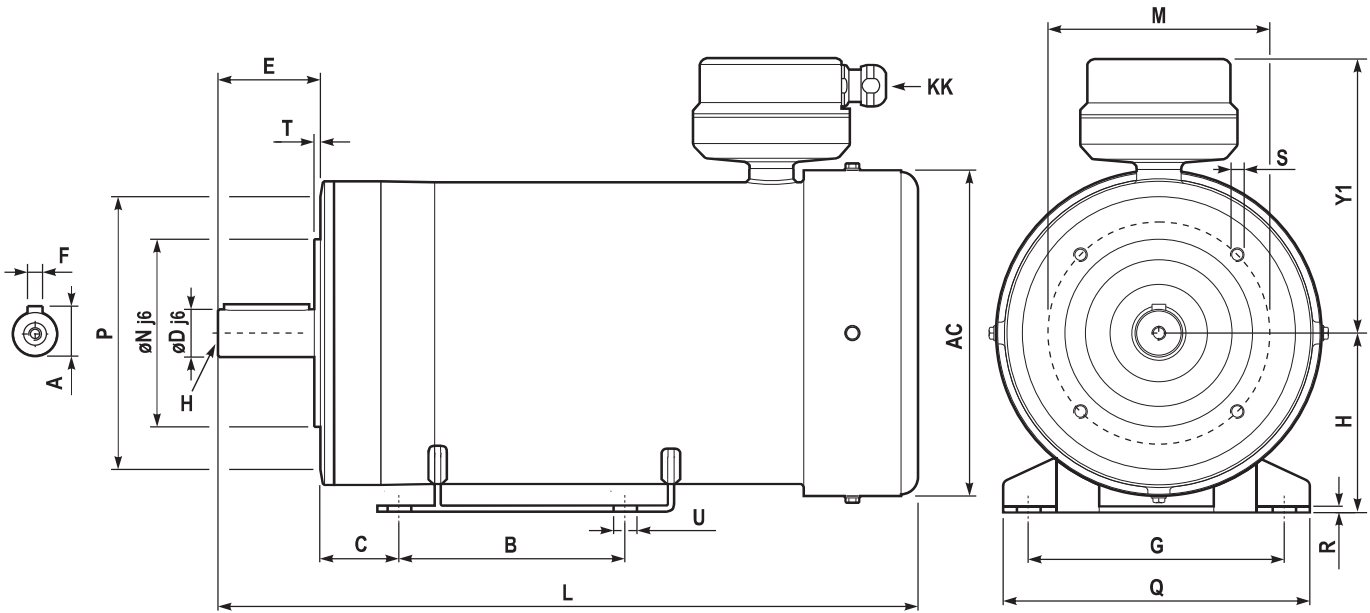

Motor fan and fan cover in stainless steel

All components of the motor fan and fan cover are made of stainless steel.
Tutti i componenti della ventola motore e copri ventola sono in acciaio inox.

Feet fixing dimensions

The dimensions of the feet are interchangeable with most brands in the market.
Le dimensioni del piedino sono intercambiabili con la maggior parte dei brand nel mercato.

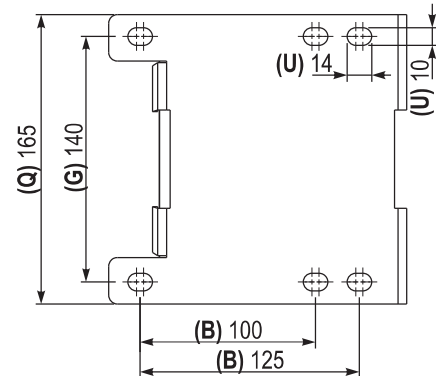

Foot dimensions

Dimensione piede

Motor	B	C	G	H	U	Q	R
100LA	100 125	56	140	100	10x14	165	4



360° orientabile

Standard with terminal box



Options With direct cable

On request with direct cable UL certified cable, resistant to hot temperature (+90°C).
A richiesta con cavo diretto certificato UL, resistente ad alte temperature (+90°C).

Dimensions

Dimensioni

Motor	2 poles kW	4 poles kW	A	∅D j6 H	E	F	L	M	∅N j6	P	S	T	AC	KK	Y1
100LA	3.0	2.2	31	∅28 M8x20	60	8	410.5	130	110	160	M8x16	3.5	191	M20x1.5	163